

## RACK CABINET

### INTELLIGENT COOLING SYSTEM (AGILE)

It is designed to enable all active and passive devices to be protected thanks to its aesthetic appearance, high quality design and manufacturing which will be used in office applications.



**Digital thermostat** smart system  
and Remote **Control Systems**  
Rack Cabinet

- TSM-FRK 16U
- TSM-FRK 20U
- TSM-FRK 22U
- TSM-FRK 26U
- TSM-FRK 32U
- TSM-FRK 36U
- TSM-FRK 42U
- TSM-FRK 44U



### PRACTICAL AND ERGONOMIC

design, all brands and models are manufactured with active and passive ventilation and traceability in every detail accessories that you can install active and passive devices.

The digital temperature sensor measures the temperature of the heat and Fan 1 and 2 enter the circuit at the specified temperature intervals. At extremely high temperatures the Buzzer Alarm is switched on and the warning buzzer sounds.

- Temperature Sensor
- Digital Indicator
- Dual System Cooling Fan With 2 And 4
- Temperature Analysis
- Remote Access



## 19" RACK CABINET 600x600

Free Standing Rack Cabinet

### Network/Server cabinets,

Quality and value added in the most optimal way.

Parallel to the high performance and quality of its network applications, fully automatic industrial infrastructure and design create an unbelievable price index and offer the customer likes.



### In the 600mm wide range,

From 16U to 44U, 8 different depths are offered. The cabinets are supplied as standard with glass front door, mechanical interlock, locked metal side panels and a locked metal rear door. All panels and doors are lockable.

### Wide product height portfolio,

Everything you need for your infrastructure meets the need for height.

In addition to its technical appearance, it also has an aesthetic appearance with decorative extrusion aluminum front door frame.

Completely standard and stocked product portfolio is shipped pre-assembled and disassembled.

The height adjustment foot is not included in the dispatch configuration.

It is offered with the quality to meet all usage demands and various accessory options and most suitable for height usage area.

**RAL 9005**  
Black

**RAL 7035**  
Light Grey



## 19" RACK CABINET 600x600

Free Standing Rack Cabinet

### DETAILS

19" Stylish type modular rack cabinet – All steel construction - Ergonomic design - Carrying frame is steel construction with 1.5mm thickness - Openable and lockable side and back covers - Adjustable rack mounting brackets at the desired level - 800 kg carrying capacity - Easy assembling - An optional fan unit can be installed in the ceiling - The front door is supported by 4 mm tempered glass and sheet frame - Lower and upper cable entries – Standard colors ral 9005, 7035 and 7032 - Dismounted at freight costs: 50% savings, convenient price





## 19" RACK CABINET 600x600

Free Standing Rack Cabinet

### TECNICAL DETAILS

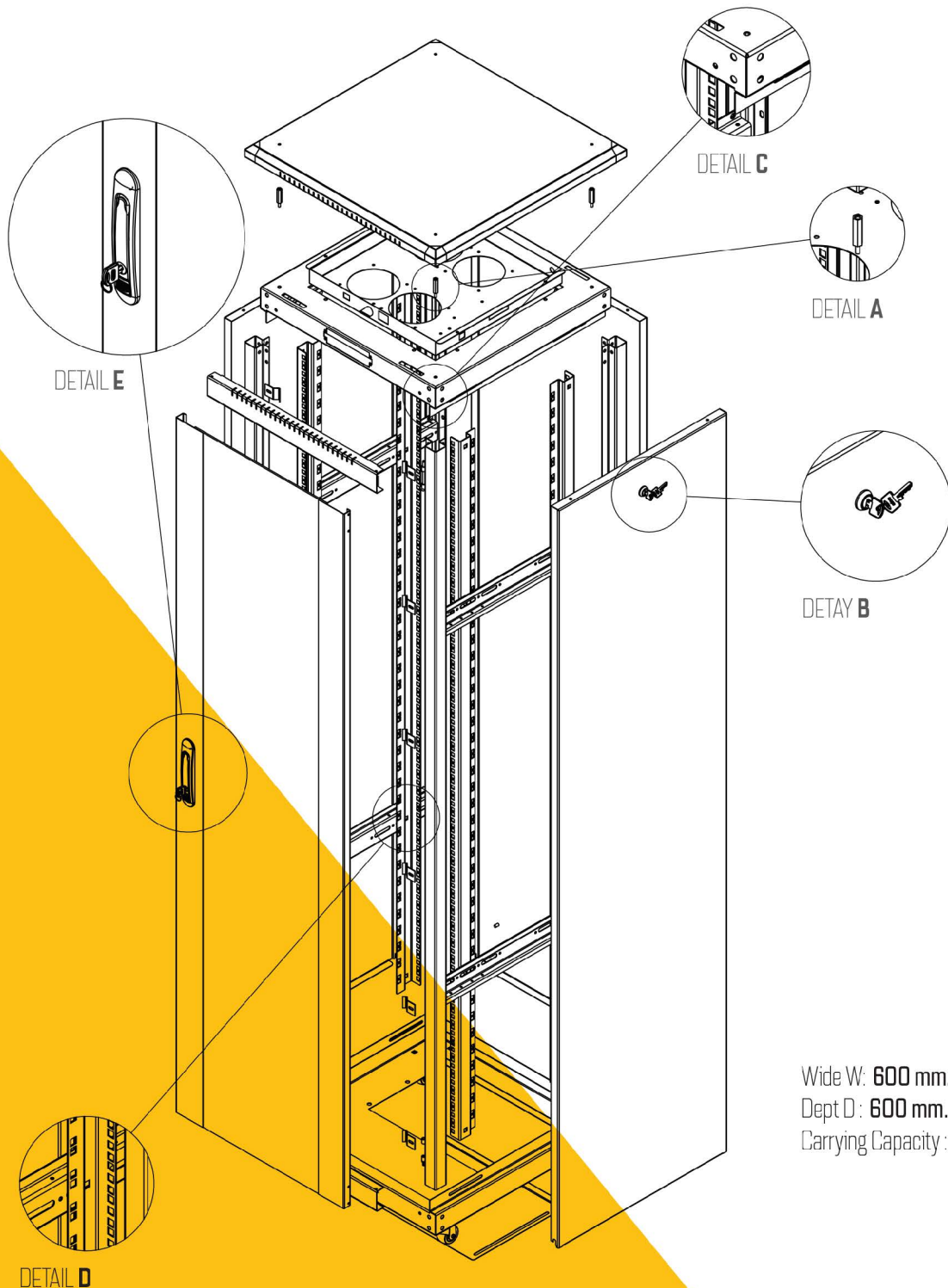

Wide W: 600 mm.  
Dept D: 600 mm.  
Carrying Capacity: 500 kg.



## 19" RACK CABINET 600x600

Free Standing Rack Cabinet

### TECNICAL DETAILS

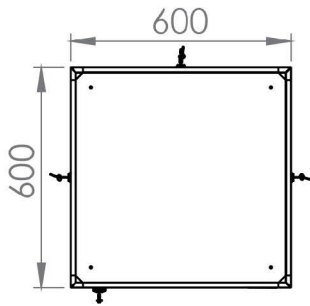

TOP VIEW

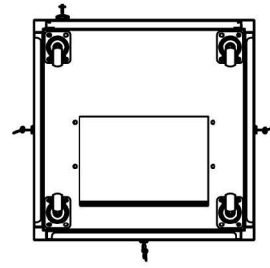

BOTTOM VIEW

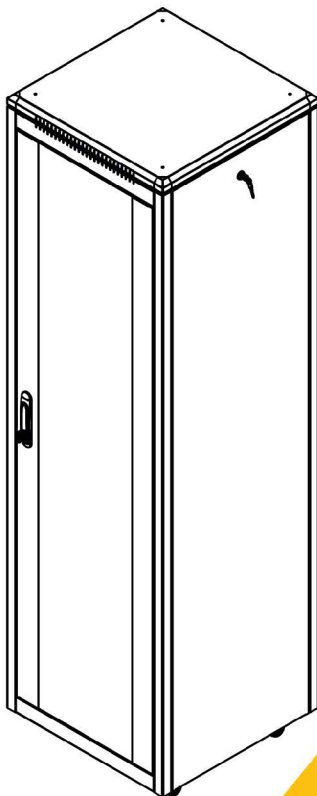

ISOMETRIC APPEARANCE

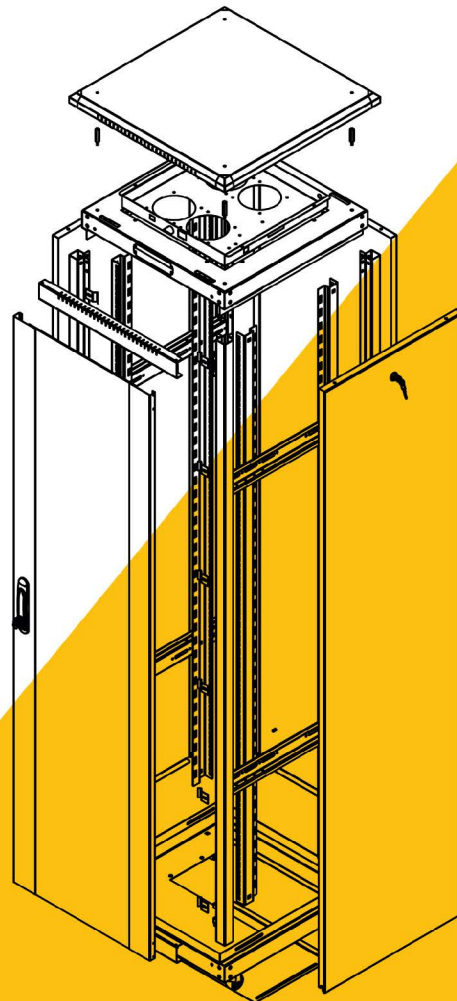

ISOMETRIC DECONATED APPEARANCE

## 19" RACK CABINET 600x600

Free Standing Rack Cabinet

### TECHNICAL DETAILS

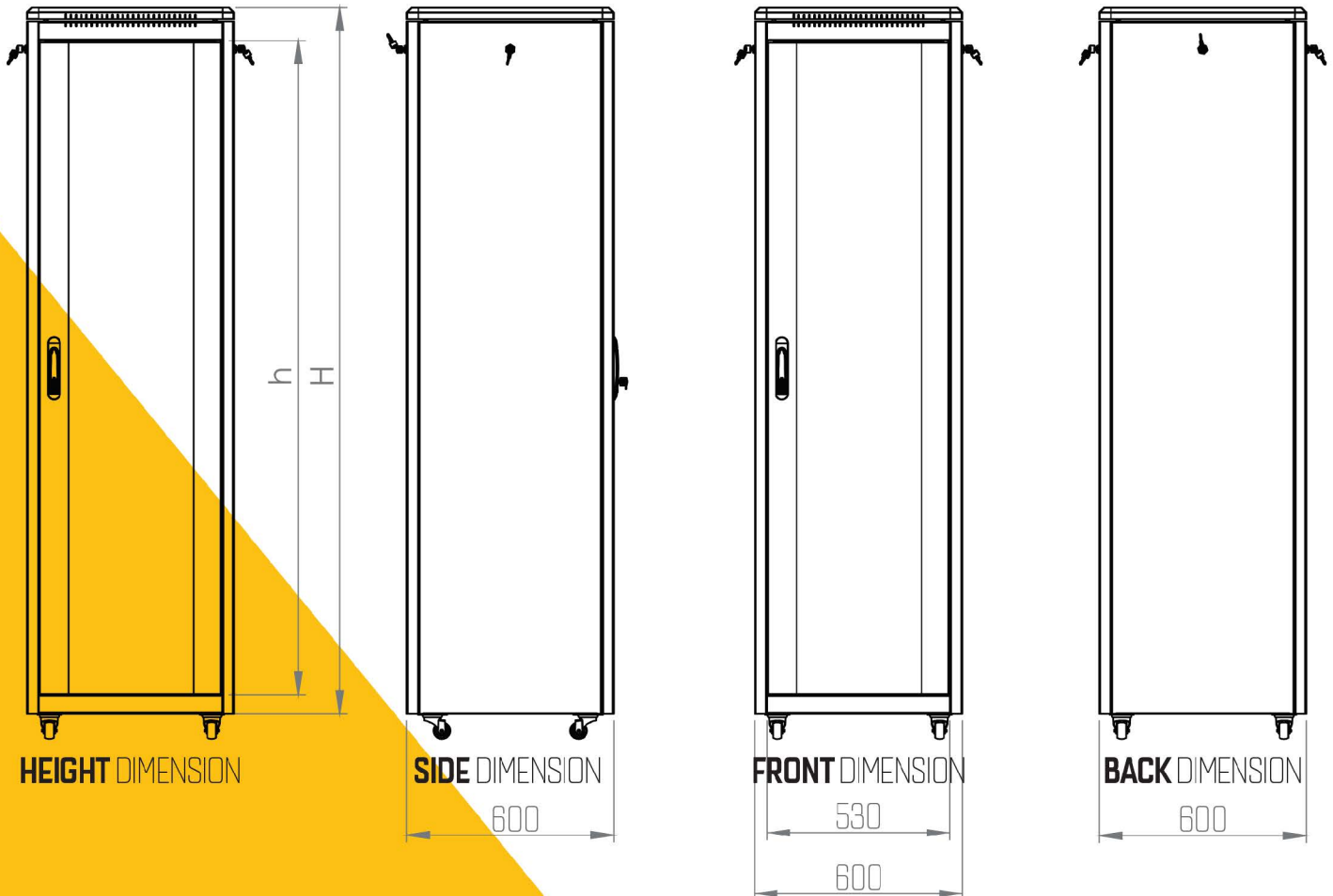

Product Code	Description	Stock Code	Dimension wxdxh Mm	h Dimension U	h mm	H mm Outside Outside Wheel and Footless Measure Wheels 90 mm	Wide mm	Wide Device	Between The Bins Depth Mm	Amount in Packing	Packing Dimension WxDxH mm	Net Product Weight G.	Gross Product Weight G.
TSRK-16U6060	16U 19" Free Standing Cabinet W: 600mm D: 600 mm	17001	600x600x885	16U	740	885	600	19"	600	1	620x620x905	32.000	32.000
TSRK-20U6060	20U 19" Free Standing Cabinet W: 600mm D: 600 mm	17002	600x600x1066	20U	915	1066	600	19"	600	1	620x620x1086	40.000	40.000
TSRK-22U6060	22U 19" Free Standing Cabinet W: 600mm D: 600 mm	17003	600x600x1155	22U	1004	1155	600	19"	600	1	620x620x1175	44.000	44.000
TSRK-26U6060	26U 19" Free Standing Cabinet W: 600mm D: 600 mm	17004	600x600x1333	26U	1182	1333	600	19"	600	1	620x620x1353	52.000	52.000
TSRK-32U6060	32U 19" Free Standing Cabinet W: 600mm D: 600 mm	17005	600x600x1600	32U	1450	1600	600	19"	600	1	620x620x1620	64.000	64.000
TSRK-36U6060	36U 19" Free Standing Cabinet W: 600mm D: 600 mm	17006	600x600x1780	36U	1625	1780	600	19"	600	1	620x620x1800	72.000	72.000
TSRK-42U6060	42U 19" Free Standing Cabinet W: 600mm D: 600 mm	17007	600x600x2045	42U	1895	2045	600	19"	600	1	620x620x2065	84.000	84.000
TSRK-44U6060	44U 19" Free Standing Cabinet W: 600mm D: 600 mm	17008	600x600x2130	44U	1985	2130	600	19"	600	1	620x620x2150	88.000	88.000

## 19" RACK CABINET 600x800

Free Standing Rack Cabinet

### Network/Server cabinets,

Quality and value added in the most optimal way.

Parallel to the high performance and quality of its network applications, fully automatic industrial infrastructure and design create an unbelievable price index and offer the customer likes.



### In the 600mm wide range,

From 16U to 44U, 8 different depths are offered. The cabinets are supplied as standard with glass front door, mechanical interlock, locked metal side panels and a locked metal rear door. All panels and doors are lockable.

### Wide product height portfolio,

Everything you need for your infrastructure meets the need for height.

In addition to its technical appearance, it also has an aesthetic appearance with decorative extrusion aluminum front door frame.

Completely standard and stocked product portfolio is shipped pre-assembled and disassembled.

The height adjustment foot is not included in the dispatch configuration.

It is offered with the quality to meet all usage demands and various accessory options and most suitable for height usage area.

RAL 9005  
Black





## 19" RACK CABINET 600x800

Free Standing Rack Cabinet

### DETAILS

19" Stylish type modular rack cabinet – All steel construction - Ergonomic design - Carrying frame is steel construction with 1.5mm thickness - Openable and lockable side and back covers - Adjustable rack mounting brackets at the desired level - 800 kg carrying capacity - Easy assembling - An optional fan unit can be installed in the ceiling - The front door is supported by 4 mm tempered glass and sheet frame - Lower and upper cable entries – Standart colors ral 9005, 7035 and 7032 - Dismounted at freight costs: 50% savings, convenient price

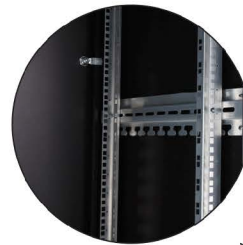

## 19" RACK CABINET 600x800

Free Standing Rack Cabinet

### TECNICAL DETAILS

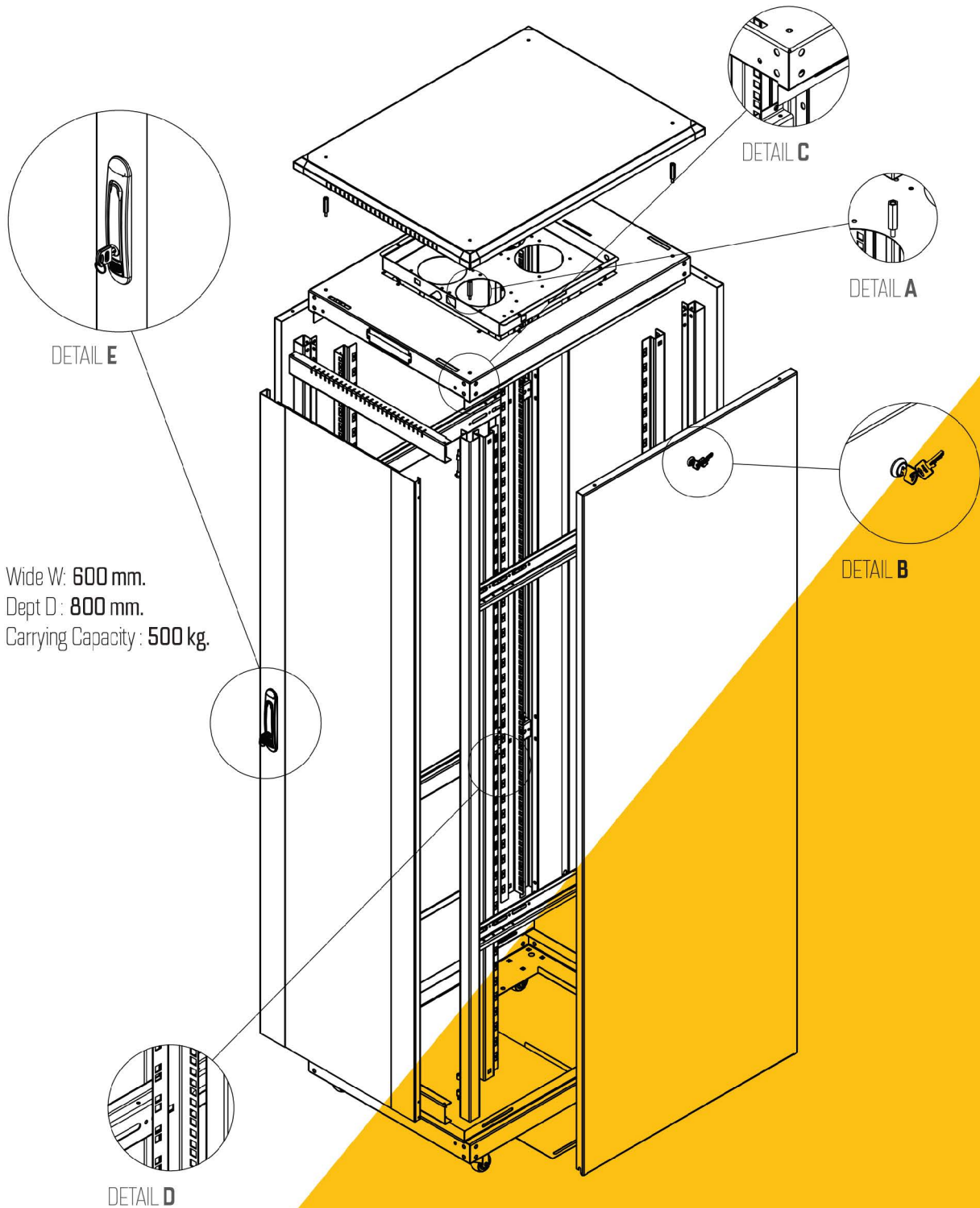

## 19" RACK CABINET 600x800

Free Standing Rack Cabinet

### TECNICAL DETAILS

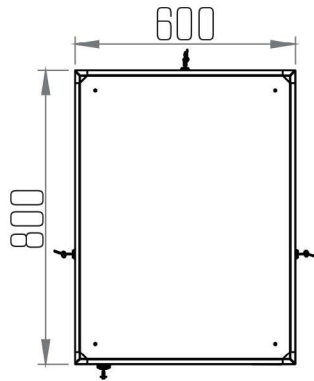

TOPVIEW

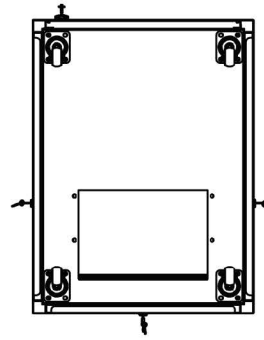

BOTTOMVIEW

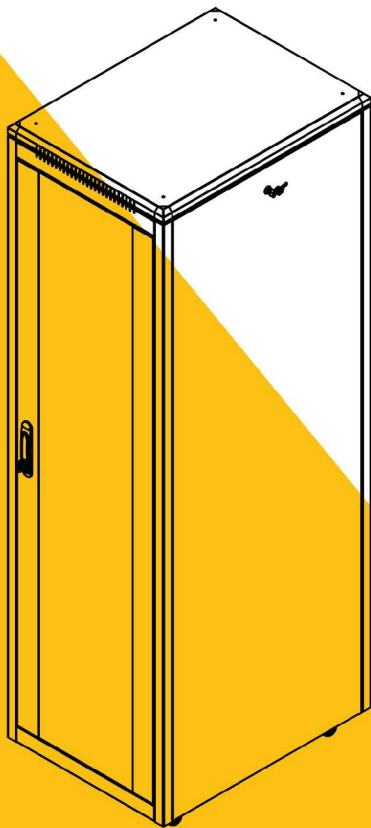

ISOMETRIC APPEARANCE

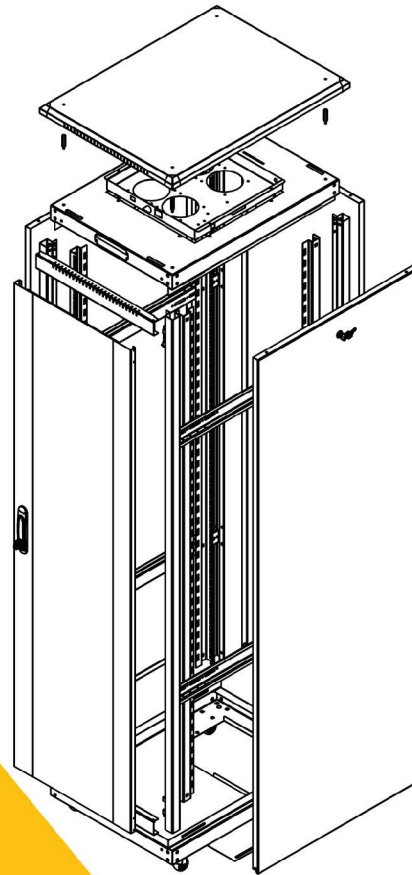

ISOMETRIC DECONATED APPEARANCE



## 19" RACK CABINET 600x800

Free Standing Rack Cabinet

### TECNICAL DETAILS

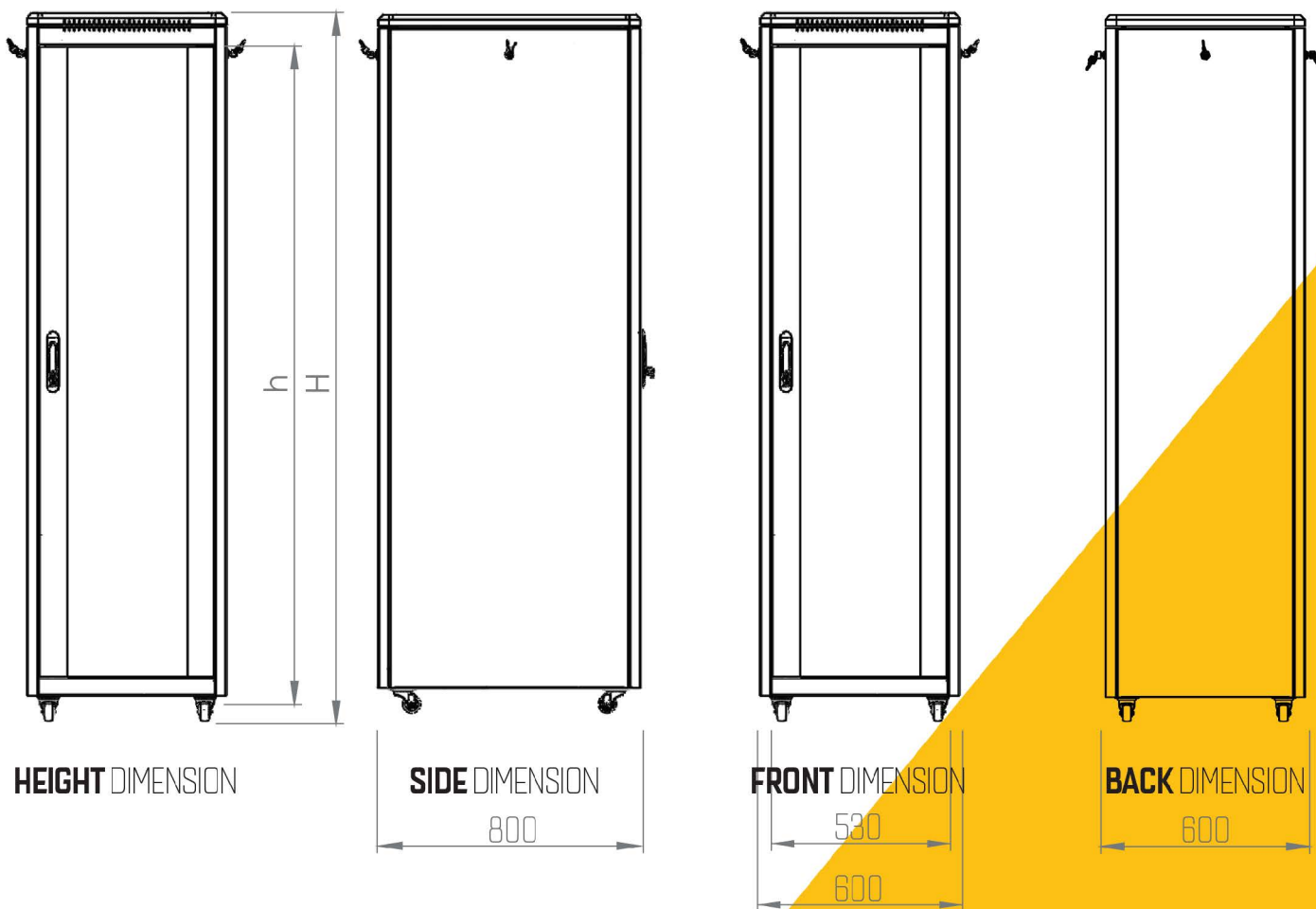

Product Code	Description	Stock Code	Dimension wxdxh Mm	h Dimension U	h mm	H mm Outside TWheel and Footless Measure Wheels 90 mm	Wide mm	Wide Device	Between The Bins Depth Mm	Amount in Packing	Packing Dimension WxDxH mm	Net Product Weight G.	Gros Product Weight G.
TSRK-16U6080	16U 19" Free Standing Cabinet W: 600mm D: 800 mm	17011	600x800x885	16U	740	885	600	19"	800	1	620x820x905	40.000	40.000
TSRK-20U6080	20U 19" Free Standing Cabinet W: 600mm D: 800 mm	17012	600x800x1066	20U	915	1066	600	19"	800	1	620x820x1086	50.000	50.000
TSRK-22U6080	22U 19" Free Standing Cabinet W: 600mm D: 800 mm	17013	600x800x1155	22U	1004	1155	600	19"	800	1	620x820x1175	55.000	55.000
TSRK-26U6080	26U 19" Free Standing Cabinet W: 600mm D: 800 mm	17014	600x800x1333	26U	1182	1333	600	19"	800	1	620x820x1353	65.000	65.000
TSRK-32U6080	32U 19" Free Standing Cabinet W: 600mm D: 800 mm	17015	600x800x1600	32U	1450	1600	600	19"	800	1	620x820x1620	80.000	80.000
TSRK-36U6080	36U 19" Free Standing Cabinet W: 600mm D: 800 mm	17016	600x800x1780	36U	1625	1780	600	19"	800	1	620x820x1800	90.000	90.000
TSRK-42U6080	42U 19" Free Standing Cabinet W: 600mm D: 800 mm	17017	600x800x2045	42U	1895	2045	600	19"	800	1	620x820x2065	105.000	105.000
TSRK-44U6080	44U 19" Free Standing Cabinet W: 600mm D: 800 mm	17018	600x800x2130	44U	1985	2130	600	19"	800	1	620x820x2150	110.000	110.000

## 19" RACK CABINET 600x1000

Free Standing Rack Cabinet

### Network/Server cabinets,

Quality and value added in the most optimal way.

Parallel to the high performance and quality of its network applications, fully automatic industrial infrastructure and design create an unbelievable price index and offer the customer likes.



### In the 600mm wide range,

From 16U to 44U, 8 different depths are offered. The cabinets are supplied as standard with glass front door, mechanical interlock, locked metal side panels and a locked metal rear door. All panels and doors are lockable.

### Wide product height portfolio,

Everything you need for your infrastructure meets the need for height.

In addition to its technical appearance, it also has an aesthetic appearance with decorative extrusion aluminum front door frame.

Completely standard and stocked product portfolio is shipped pre-assembled and disassembled.

The height adjustment foot is not included in the dispatch configuration.

It is offered with the quality to meet all usage demands and various accessory options and most suitable for height usage area.

**RAL 9005**  
Black

**RAL 7035**  
Light Grey



## 19" RACK CABINET 600x1000

Free Standing Rack Cabinet

### DETAILS

19" Stylish type modular rack cabinet – All steel construction - Ergonomic design - Carrying frame is steel construction with 1.5mm thickness - Openable and lockable side and back covers - Adjustable rack mounting brackets at the desired level - 800 kg carrying capacity - Easy assembling - An optional fan unit can be installed in the ceiling - The front door is supported by 4 mm tempered glass and sheet frame - Lower and upper cable entries – Standard colors ral 9005, 7035 and 7032 - Dismounted at freight costs: 50% savings, convenient price





## 19" RACK CABINET 600x1000

Free Standing Rack Cabinet

### TECNICAL DETAILS

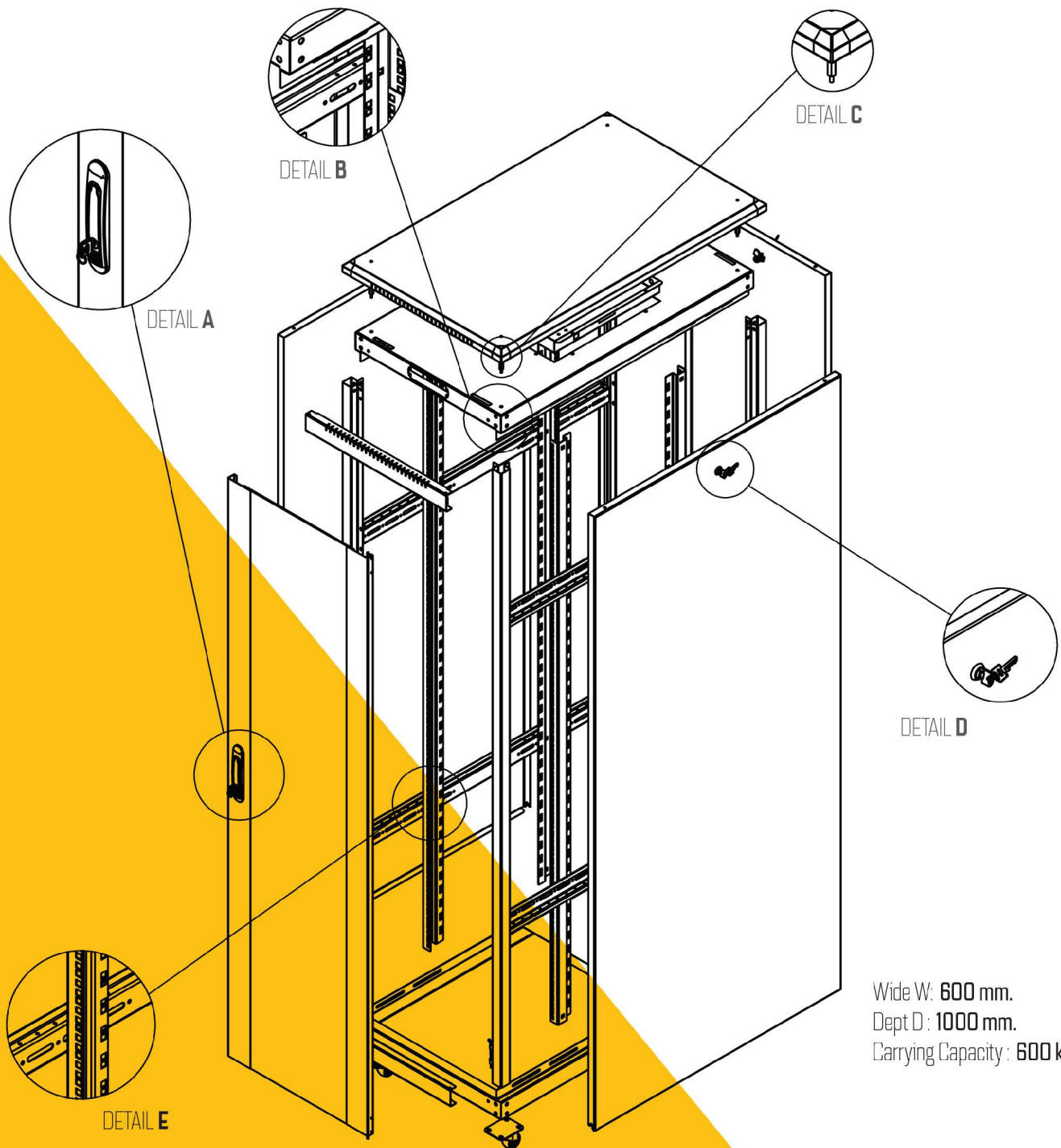

Wide W: 600 mm.  
Dept D: 1000 mm.  
Carrying Capacity: 600 kg.

## 19" RACK CABINET 600x1000

Free Standing Rack Cabinet

### TECNICAL DETAILS

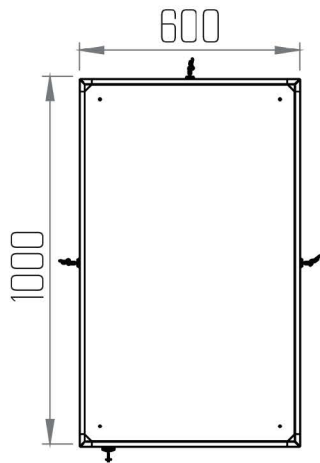

TOPVIEW

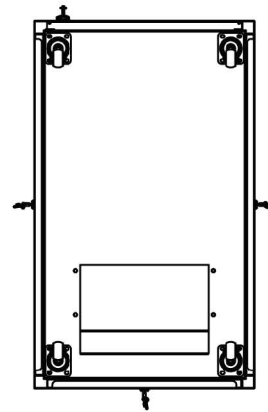

BOTTOMVIEW

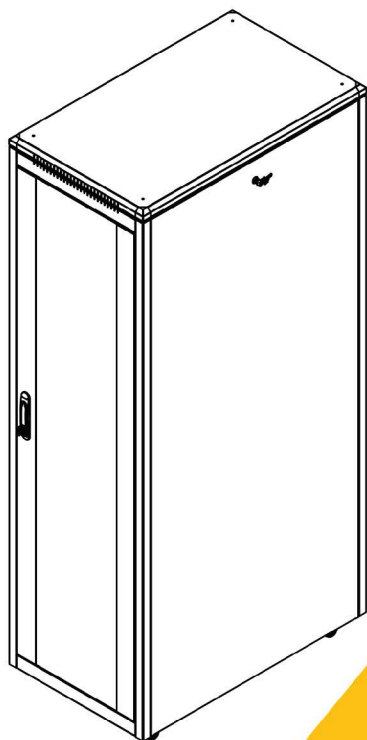

ISOMETRIC APPEARANCE

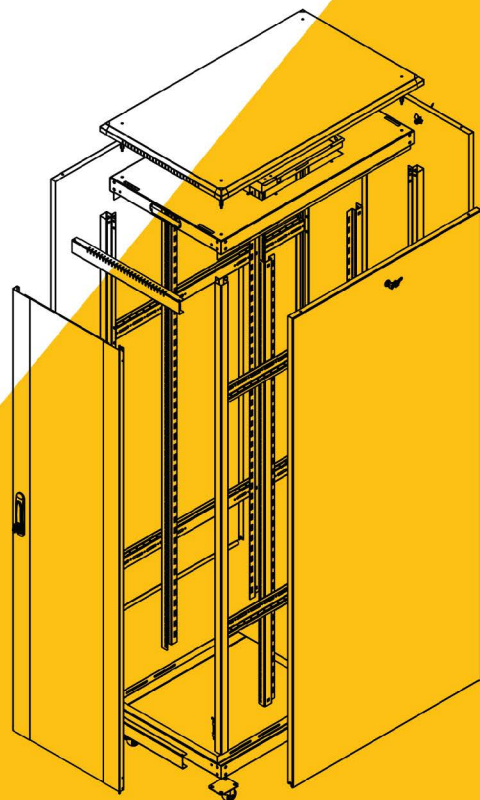

ISOMETRIC DECONATED APPEARANCE

## 19" RACK CABINET 600x1000

Free Standing Rack Cabinet

### TECNICAL DETAILS

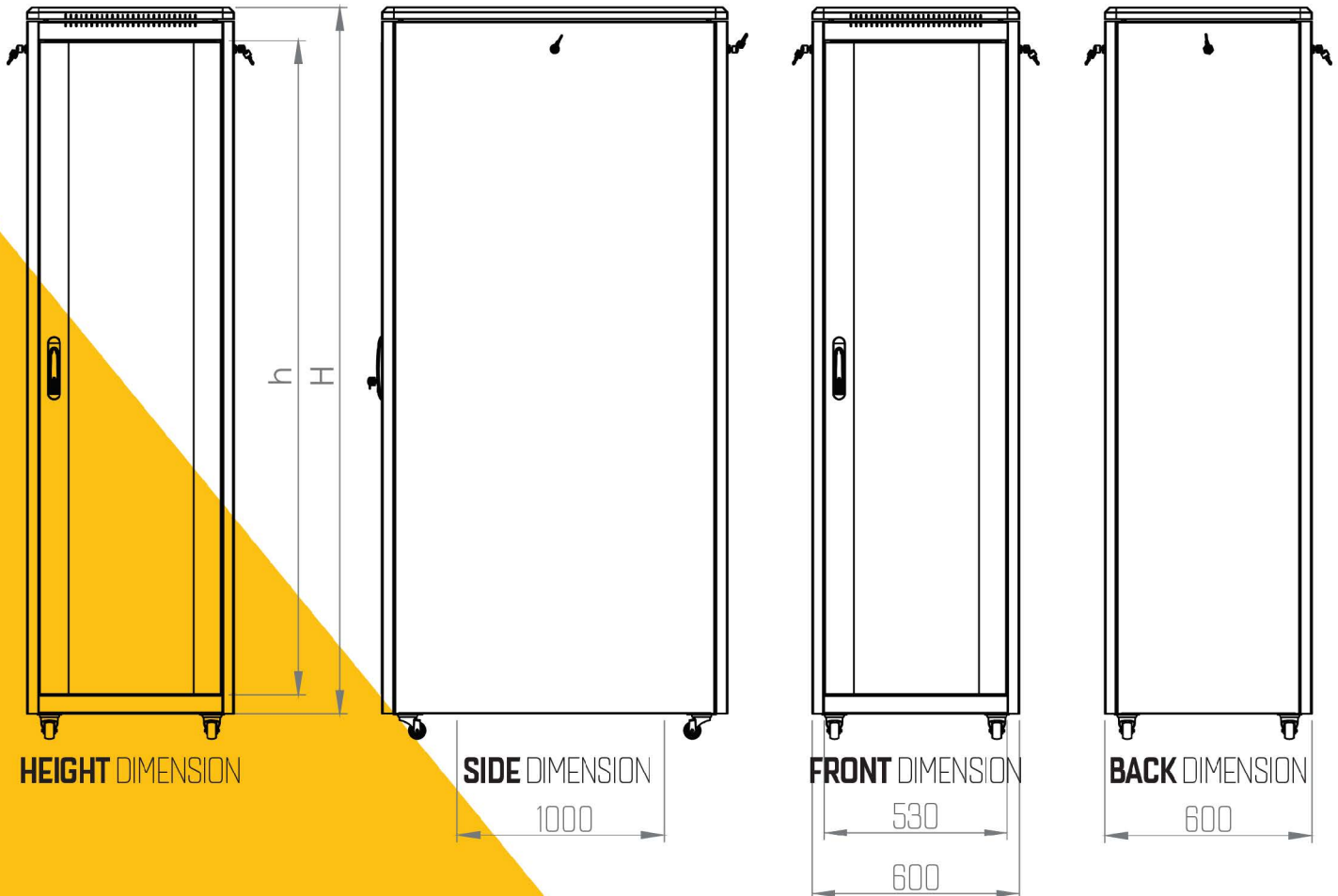

Product Code	Description	Stock Code	Dimension wxdxh Mm	h Dimension U	h mm	H mm Outside Outside TV Wheel and Footless Measure Wheel 90 mm	Wide mm	Wide Device	Between The Bms Depth Mm	Amount In Packing	Packing Dimension WxDxH mm	Net Product Weight G.	Gros Product Weight G.
TSRK-16U60100	16U 19" Free Standing Cabinet W: 600mm D: 1000 mm	17021	600x1000x885	16U	740	885	600	19"	1000	1	620x1020x905	48.000	48.000
TSRK-20U60100	20U 19" Free Standing Cabinet W: 600mm D: 1000 mm	17022	600x1000x1066	20U	915	1066	600	19"	1000	1	620x1020x1086	60.000	60.000
TSRK-22U60100	22U 19" Free Standing Cabinet W: 600mm D: 1000 mm	17023	600x1000x1155	22U	1004	1155	600	19"	1000	1	620x1020x1175	66.000	66.000
TSRK-26U60100	26U 19" Free Standing Cabinet W: 600mm D: 1000 mm	17024	600x1000x1333	26U	1182	1333	600	19"	1000	1	620x1020x1353	78.000	78.000
TSRK-32U60100	32U 19" Free Standing Cabinet W: 600mm D: 1000 mm	17025	600x1000x1600	32U	1450	1600	600	19"	1000	1	620x1020x1620	96.000	96.000
TSRK-36U60100	36U 19" Free Standing Cabinet W: 600mm D: 1000 mm	17026	600x1000x1780	36U	1625	1780	600	19"	1000	1	620x1020x1800	108.000	108.000
TSRK-42U60100	42U 19" Free Standing Cabinet W: 600mm D: 1000 mm	17027	600x1000x2045	42U	1895	2045	600	19"	1000	1	620x1020x2065	126.000	126.000
TSRK-44U60100	44U 19" Free Standing Cabinet W: 600mm D: 1000 mm	17028	600x1000x2130	44U	1985	2130	600	19"	1000	1	620x1020x2150	132.000	132.000



## 19" RACK CABINET 800x800

Free Standing Rack Cabinet

### Network/Server cabinets,

Quality and value added in the most optimal way.

Parallel to the high performance and quality of its network applications, fully automatic industrial infrastructure and design create an unbelievable price index and offer the customer likes.



- **In the 600mm wide range,** From 16U to 44U, 8 different depths are offered. The cabinets are supplied as standard with glass front door, mechanical interlock, locked metal side panels and a locked metal rear door. All panels and doors are lockable.

**RAL 9005**  
Black

**RAL 7035**  
Light Grey

### Wide product height portfolio,

Everything you need for your infrastructure meets the need for height.

In addition to its technical appearance, it also has an aesthetic appearance with decorative extrusion aluminum front door frame.

Completely standard and stocked product portfolio is shipped pre-assembled and disassembled.

The height adjustment foot is not included in the dispatch configuration.

It is offered with the quality to meet all usage demands and various accessory options and most suitable for height usage area.



# 19" RACK CABINET

## 800x800

Free Standing Rack Cabinet

### DETAILS

19 " Stylish type modular rack cabinet – All steel construction - Ergonomic design - Carrying frame is steel construction with 1.5mm thickness - Openable and lockable side and back covers - Adjustable rack mounting brackets at the desired level - 800 kg carrying capacity - Easy assembling - An optional fan unit can be installed in the ceiling - The front door is supported by 4 mm tempered glass and sheet frame - Lower and upper cable entries – Standart colors ral 9005, 7035 and 7032 - Dismounted at freight costs: 50% savings, convenient price

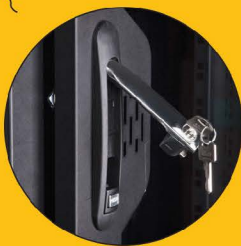

## 19" RACK CABINET 800x800

Free Standing Rack Cabinet

### TECNICAL DETAILS

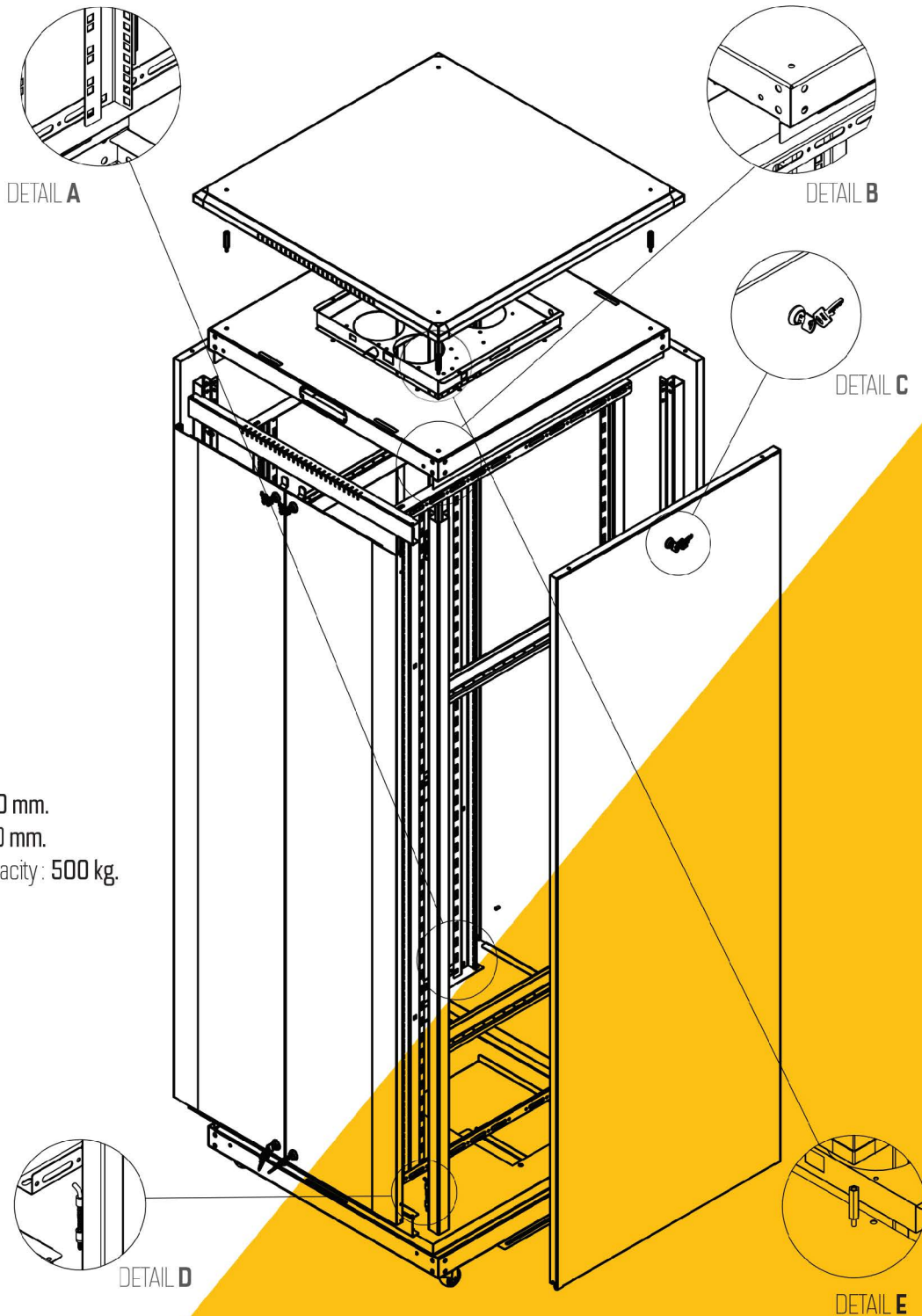

Wide W: 800 mm.  
Dept D: 800 mm.  
Carrying Capacity: 500 kg.



## 19" RACK CABINET 800x800

Free Standing Rack Cabinet

### TECNICAL DETAILS

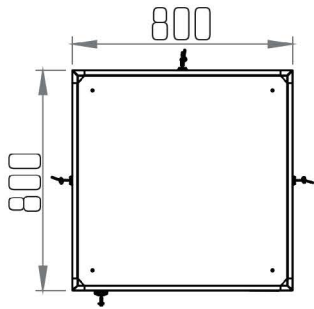

TOP VIEW

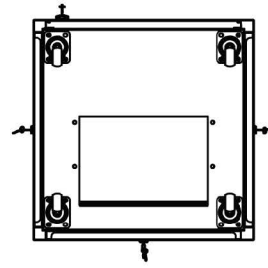

BOTTOM VIEW

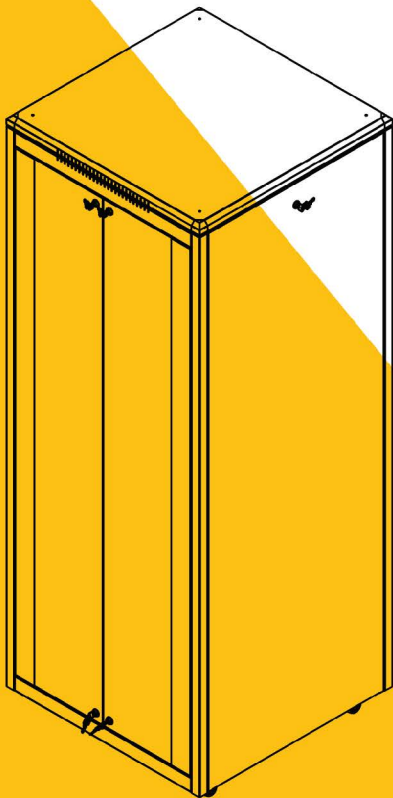

ISOMETRIC APPEARANCE

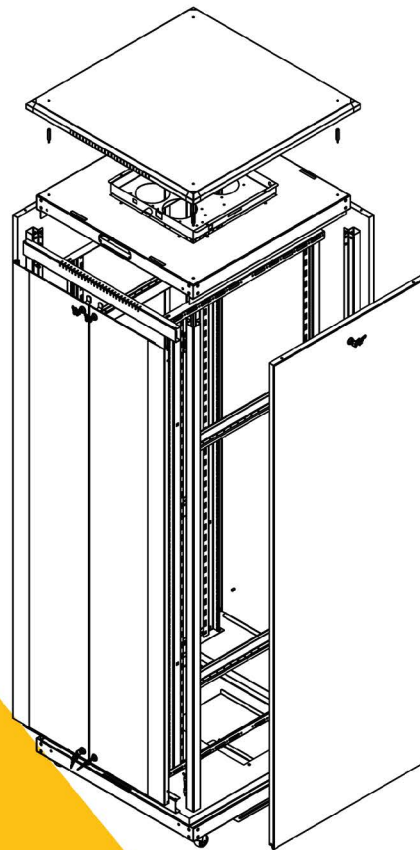

ISOMETRIC DECONATED APPEARANCE

## 19" RACK CABINET 800x800

Free Standing Rack Cabinet

### TECNICAL DETAILS

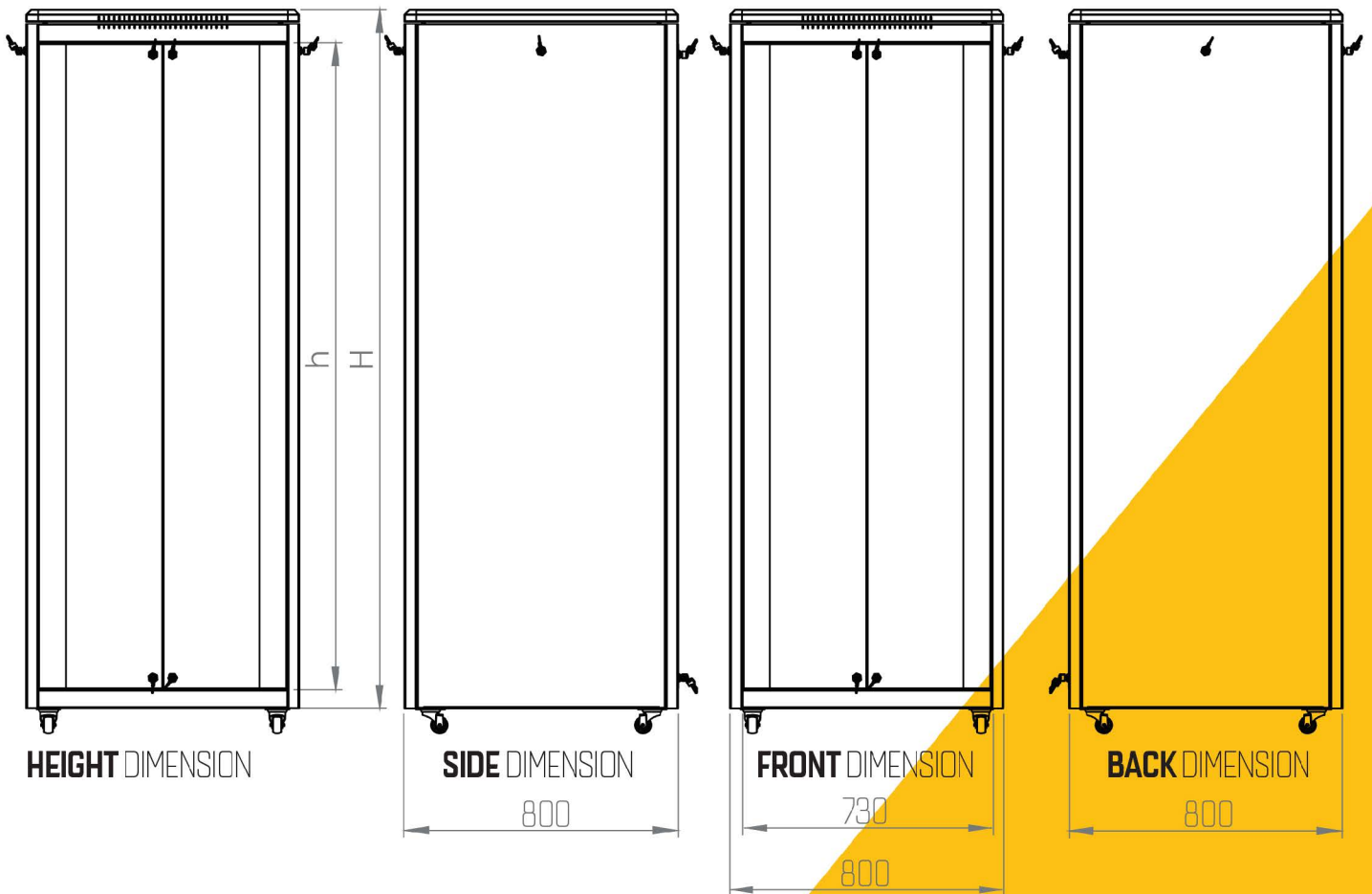

Product Code	Description	Stock Code	Dimension wxdxh Mm	h Dimension U	h mm	H mm Outside TWheel and Footless Measure Wheels 90 mm	Wide mm	Wide Device	Between The Bins Depth Mm	Amount in Packing	Packing Dimension WxDxH mm	Net Product Weight G.	Gross Product Weight G.
TSRK-16U8080	16U 19" Free Standing Cabinet W: 800mm D: 800 mm	17031	800x800x885	16U	740	885	800	19"	800	1	820x820x905	49.600	49.600
TSRK-20U8080	20U 19" Free Standing Cabinet W: 800mm D: 800 mm	17032	800x800x1066	20U	915	1066	800	19"	800	1	820x820x1086	62.000	62.000
TSRK-22U8080	22U 19" Free Standing Cabinet W: 800mm D: 800 mm	17033	800x800x1155	22U	1004	1155	800	19"	800	1	820x820x1175	68.200	68.200
TSRK-26U8080	26U 19" Free Standing Cabinet W: 800mm D: 800 mm	17034	800x800x1333	26U	1182	1333	800	19"	800	1	820x820x1353	80.600	80.600
TSRK-32U8080	32U 19" Free Standing Cabinet W: 800mm D: 800 mm	17035	800x800x1600	32U	1450	1600	800	19"	800	1	820x820x1620	99.200	99.200
TSRK-36U8080	36U 19" Free Standing Cabinet W: 800mm D: 800 mm	17036	800x800x1780	36U	1625	1780	800	19"	800	1	820x820x1800	111.600	111.600
TSRK-42U8080	42U 19" Free Standing Cabinet W: 800mm D: 800 mm	17037	800x800x2045	42U	1895	2045	800	19"	800	1	820x820x2065	130.200	130.200
TSRK-44U8080	44U 19" Free Standing Cabinet W: 800mm D: 800 mm	17038	800x800x2130	44U	1985	2130	800	19"	800	1	820x820x2150	136.400	136.400

## 19" RACK CABINET 800x1000

Free Standing Rack Cabinet

### Network/Server cabinets,

Quality and value added in the most optimal way.

Parallel to the high performance and quality of its network applications, fully automatic industrial infrastructure and design create an unbelievable price index and offer the customer likes.



• **In the 600mm wide** range, From 16U to 44U, 8 different depths are offered. The cabinets are supplied as standard with glass front door, mechanical interlock, locked metal side panels and a locked metal rear door. All panels and doors are lockable.

● **RAL 9005**  
Black

● **RAL 7035**  
Light Grey

• **Wide product** height portfolio, Everything you need for your infrastructure meets the need for height. In addition to its technical appearance, it also has an aesthetic appearance with decorative extrusion aluminum front door frame.

Completely standard and stocked product portfolio is shipped pre-assembled and disassembled.

The height adjustment foot is not included in the dispatch configuration.

It is offered with the quality to meet all usage demands and various accessory options and most suitable for height usage area.





## 19" RACK CABINET 800x1000

Free Standing Rack Cabinet

### DETAILS

19" Stylish type modular rack cabinet – All steel construction - Ergonomic design - Carrying frame is steel construction with 1.5mm thickness - Openable and lockable side and back covers - Adjustable rack mounting brackets at the desired level - 800 kg carrying capacity - Easy assembling - An optional fan unit can be installed in the ceiling - The front door is supported by 4 mm tempered glass and sheet frame - Lower and upper cable entries – Standard colors ral 9005, 7035 and 7032 - Dismounted at freight costs: 50% savings, convenient price



## 19" RACK CABINET 800x1000

Free Standing Rack Cabinet

### TECNICAL DETAILS

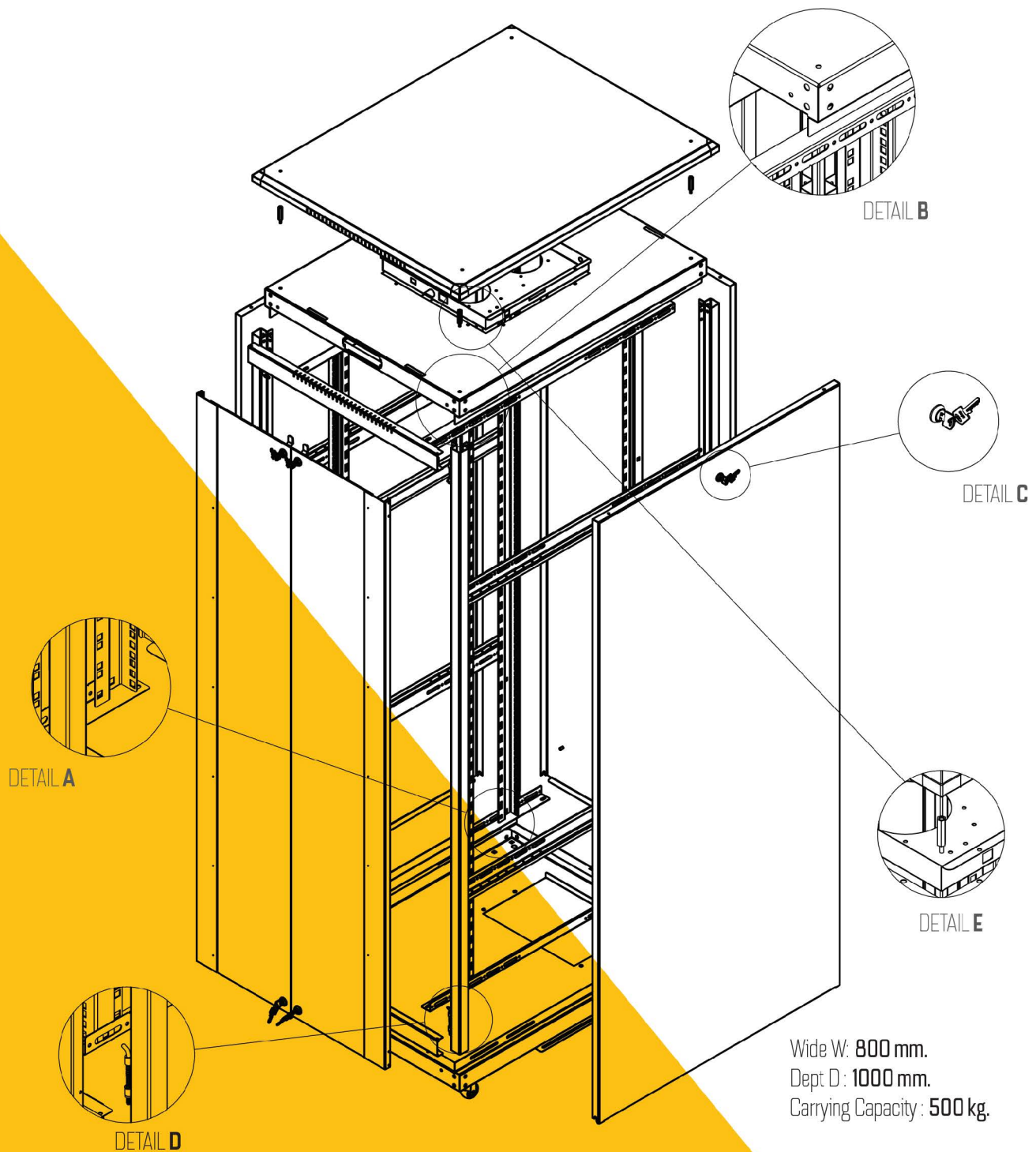

## 19" RACK CABINET 800x1000

Free Standing Rack Cabinet

### TECNICAL DETAILS

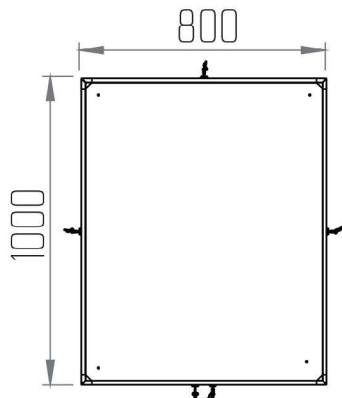

TOP VIEW

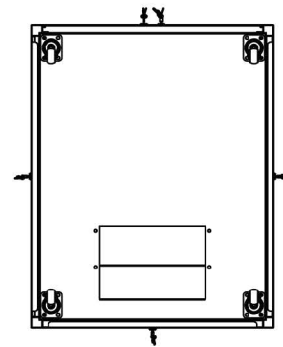

BOTTOM VIEW

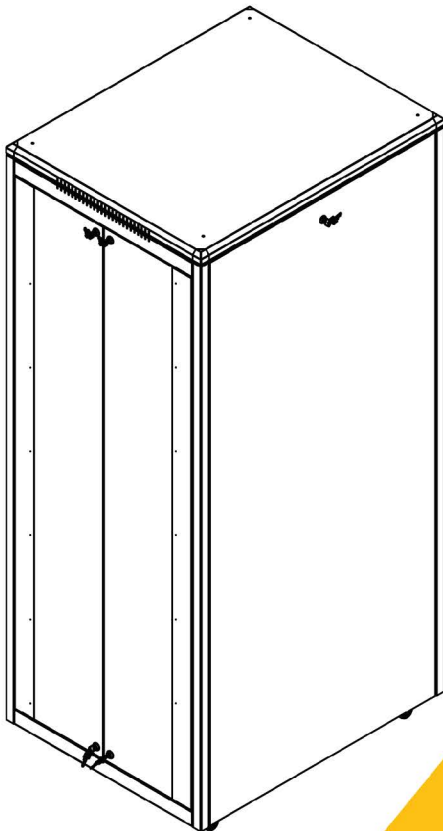

ISOMETRIC APPEARANCE

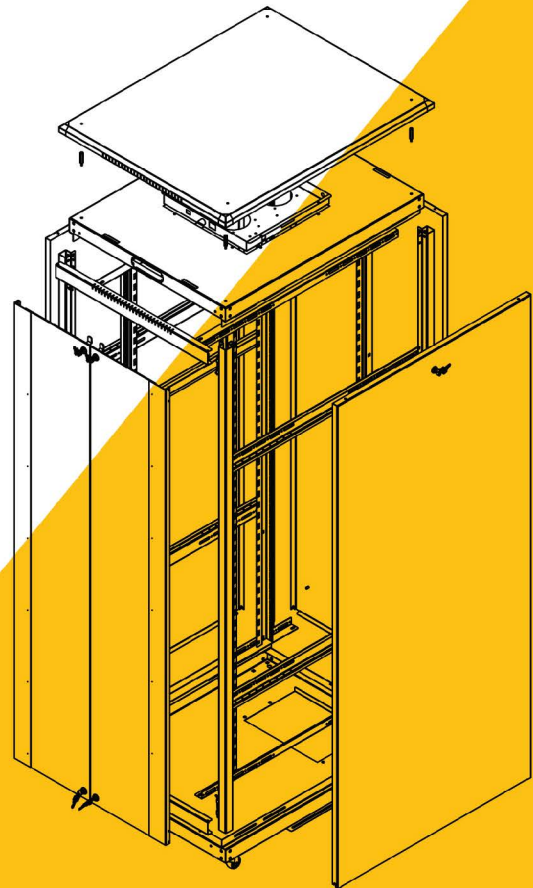

ISOMETRIC DECONATED APPEARANCE



## 19" RACK CABINET 800x1000

Free Standing Rack Cabinet

### TECHNICAL DETAILS

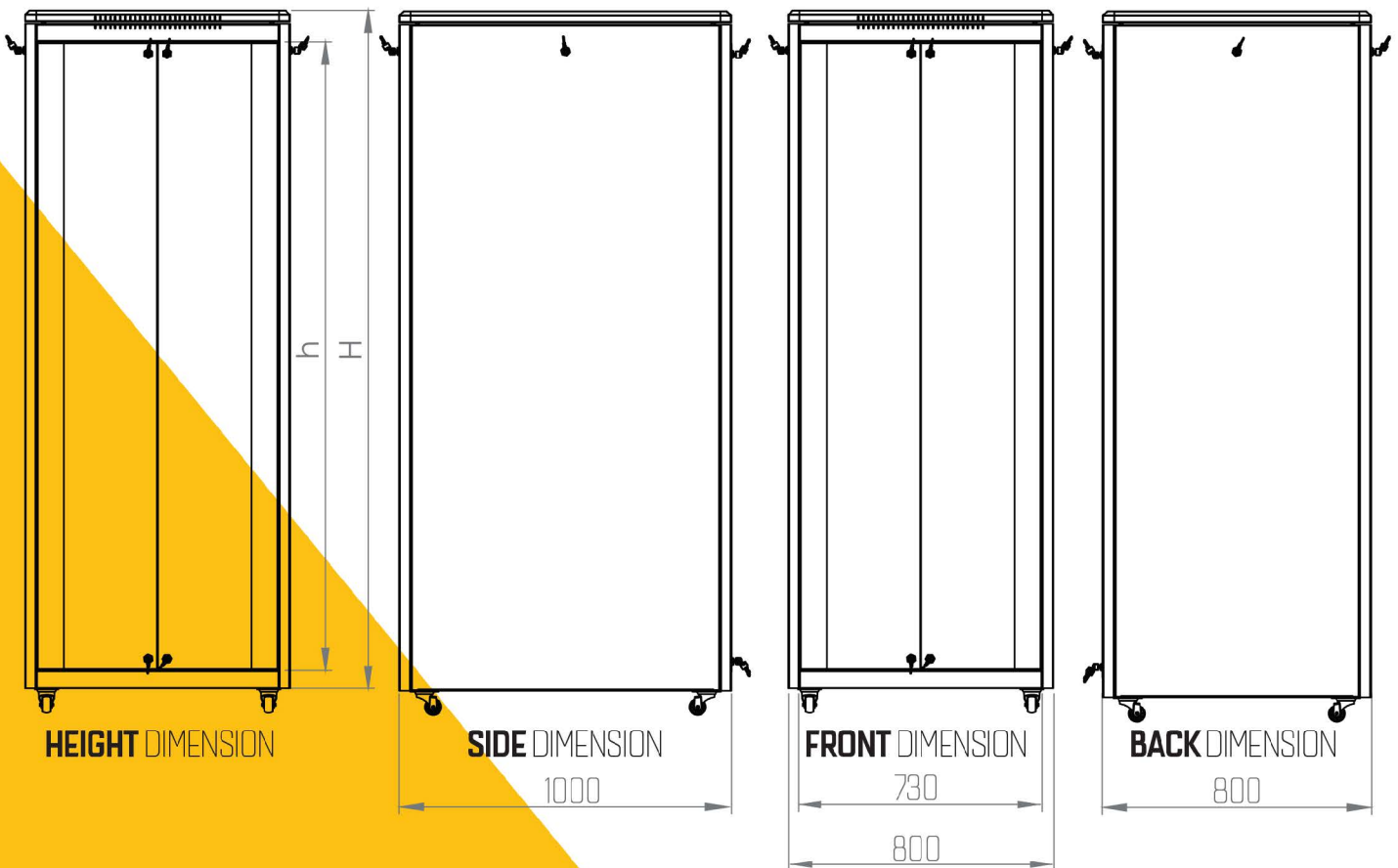

Product Code	Description	Stock Code	Dimension wxdxh Mm	h- Dimension U	h- mm	H- mm Outside Outside TV-heat and Footless Measure Wheels 90 mm	Wide mm	Wide Device	Between The Bins Depth Mm	Amount In Packing	Packing Dimension WxDxH-mm	Net-Product Weight G.	Gross Product Weight G.
TSRK-16U80100	16U 19" Free Standing Cabinet W: 800mm D: 1000 mm	17041	800x1000x885	16U	740	885	800	19"	1000	1	820x1020x905	52.800	52.800
TSRK-20U80100	20U 19" Free Standing Cabinet W: 800mm D: 1000 mm	17042	800x1000x1066	20U	915	1066	800	19"	1000	1	820x1020x1086	66.000	66.000
TSRK-22U80100	22U 19" Free Standing Cabinet W: 800mm D: 1000 mm	17043	800x1000x1155	22U	1004	1155	800	19"	1000	1	820x1020x1175	72.600	72.600
TSRK-26U80100	26U 19" Free Standing Cabinet W: 800mm D: 1000 mm	17044	800x1000x1333	26U	1182	1333	800	19"	1000	1	820x1020x1353	85.800	85.800
TSRK-32U80100	32U 19" Free Standing Cabinet W: 800mm D: 1000 mm	17045	800x1000x1600	32U	1450	1600	800	19"	1000	1	820x1020x1620	105.600	105.600
TSRK-36U80100	36U 19" Free Standing Cabinet W: 800mm D: 1000 mm	17046	800x1000x1780	36U	1625	1780	800	19"	1000	1	820x1020x1800	118.800	118.800
TSRK-42U80100	42U 19" Free Standing Cabinet W: 800mm D: 1000 mm	17047	800x1000x2045	42U	1895	2045	800	19"	1000	1	820x1020x2065	138.600	138.600
TSRK-44U80100	44U 19" Free Standing Cabinet W: 800mm D: 1000 mm	17048	800x1000x2130	44U	1985	2130	800	19"	1000	1	820x1020x2150	145.200	145.200

## RACK CABINET

### WALL TYPE

#### Network/Server cabinets,

Quality and value added in the most optimal way.

Parallel to the high performance and quality of its network applications, fully automatic industrial infrastructure and design create an unbelievable price index and offer the customer likes.

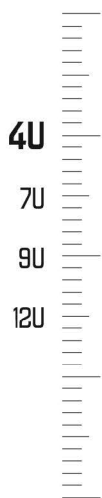

SOHO

ECO

PRO

#### ECO:

In 520X400 sizes, 4 different heights are offered up to 4,7,9,12U.

#### PRO:

600X450 and 600x600 sizes 2 kind 3 different heights are offered up to 7,9,12U.

**Eco:** Cabinets are standard mechanical lock with glass front cover.

**Pro:** In the cabins, side covers can be opened and locked.

## 19" RACK CABINET 520x400 ECO Wall Type Rack Cabinet

### Network/Server cabinets,

Quality and value added in the most optimal way.

Parallel to the high performance and quality of its network applications, fully automatic industrial infrastructure and design create an unbelievable price index and offer the customer likes.



### Rack Cabin series

Wall-type eco cabins

19 "w: 520 mm and d: 450 mm at physical dimensions is the maximum internal use depth at physical measurements offers a wide selection of users with 4 different heights

### All

Wall-mounted cabinets are shipped as standard and stocked pre-assembled in one piece and standard factory settings.

### As decorative

are presented with special design parts and accessories for harmonization to your surroundings and living spaces.



RAL 9005  
Black



RAL 7035  
Light Grey





## ECO 19" RACK CABINET 520x400 Wall Type Rack Cabinet

### DETAILS

Full length, smoked, high resistance to breaking, tempered, antistatic 4,0 mm thick glazed and locked structure.

The front door is made of tempered glass. 9035 gray, 9005 textured black, there are 2 colors.

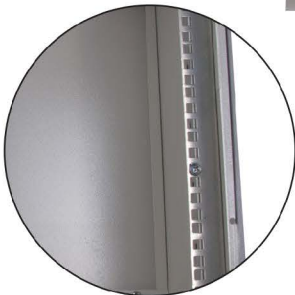

## 19" RACK CABINET 520x400 ECO Wall Type Rack Cabinet

### TECNICAL DETAILS

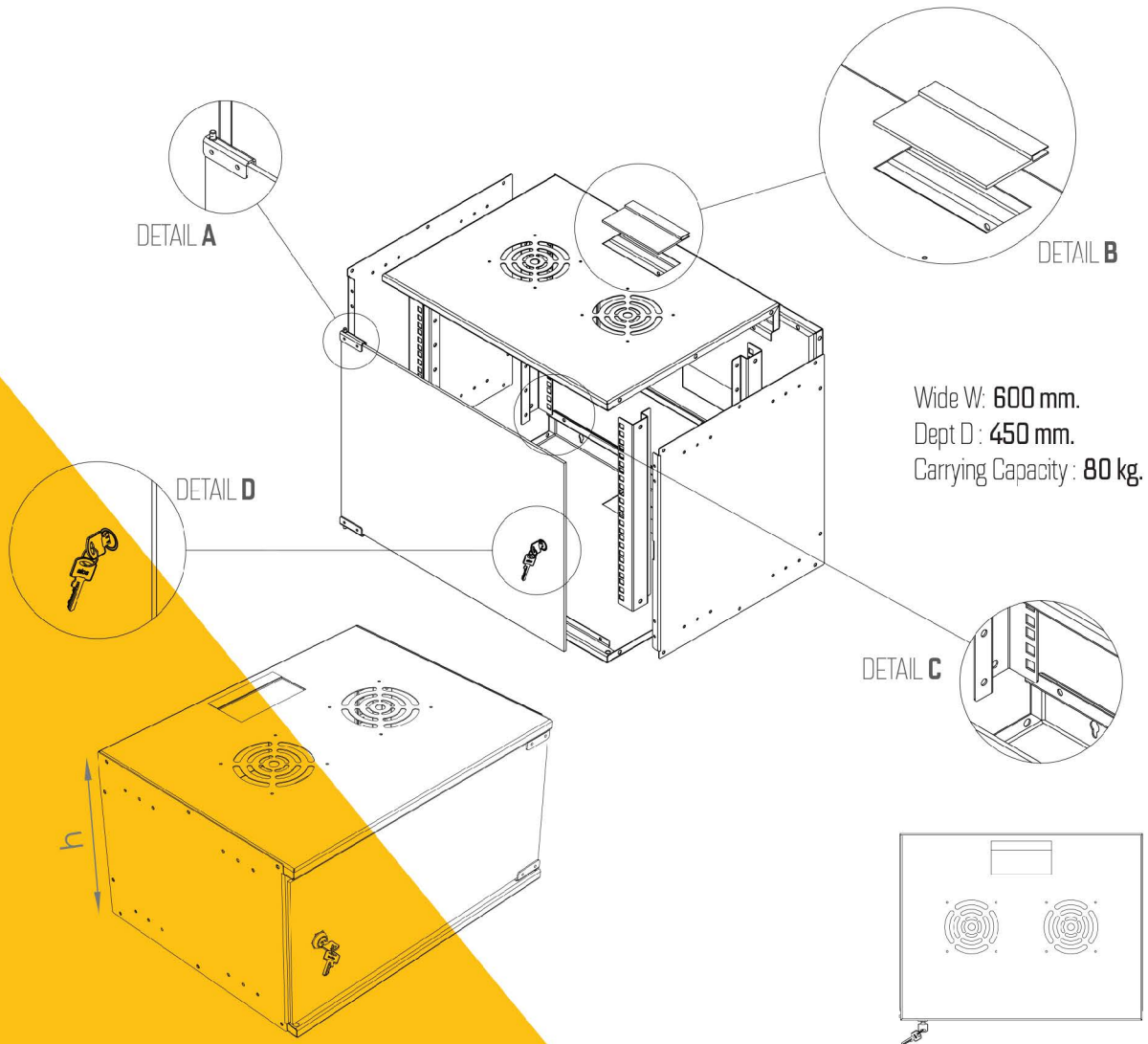

Product Code	Description	Stock Code	Dimension wdxh Mm	h Dimension U	h mm	H mm Outside	Wide mm	Wide Device	Between The Bins Depth Mm	Amount in Packing	Packing Dimension WxDxH mm	Net Product Weight G.	Gross Product Weight G.
TSEK-4U5240	4U 19" ECO WALL TYPE RACK CABINET	17051	520x400x214	4U	202	214	520	19"	400	1	540x420x234	7.900	13.000
TSEK-7U5240	7U 19" ECO WALL TYPE RACK CABINET	17052	520x400x214	7U	355	375	520	19"	400	1	540x420x1216	10.100	15.200
TSEK-9U5240	9U 19" ECO WALL TYPE RACK CABINET	17053	520x400x214	9U	457	483	520	19"	400	1	540x420x1305	11.500	16.600
TSEK-12U5240	12U 19" ECO WALL TYPE RACK CABINET	17054	520x400x214	12U	610	645	520	19"	400	1	540x420x1482	13.600	18.700

## PRO 19" RACK CABINET 600x450 Wall Type Rack Cabinet

### Network/Server cabinets,

Quality and value added in the most optimal way.

Parallel to the high performance and quality of its network applications, fully automatic industrial infrastructure and design create an unbelievable price index and offer the customer likes.



### Rack Kabin series

Wall-type eco cabins,  
19 "w: 600 mm and d: 450 mm in physical measurements, maximum internal It has a depth of usage and offers a wide selection of users with 3 different height. Ferfore door option.

### All

Wall-mounted cabinets are shipped as standard and stocked pre-assembled in one piece and standard factory settings.

### As decorative

are presented with special design parts and accessories for harmonization to your surroundings and living spaces.





## 19" RACK CABINET 600x450 PRO Wall Type Rack Cabinet

### DETAILS

Full length, smoked, high resistance to breaking, tempered, antistatic 4,0 mm thick glazed and locked structure.

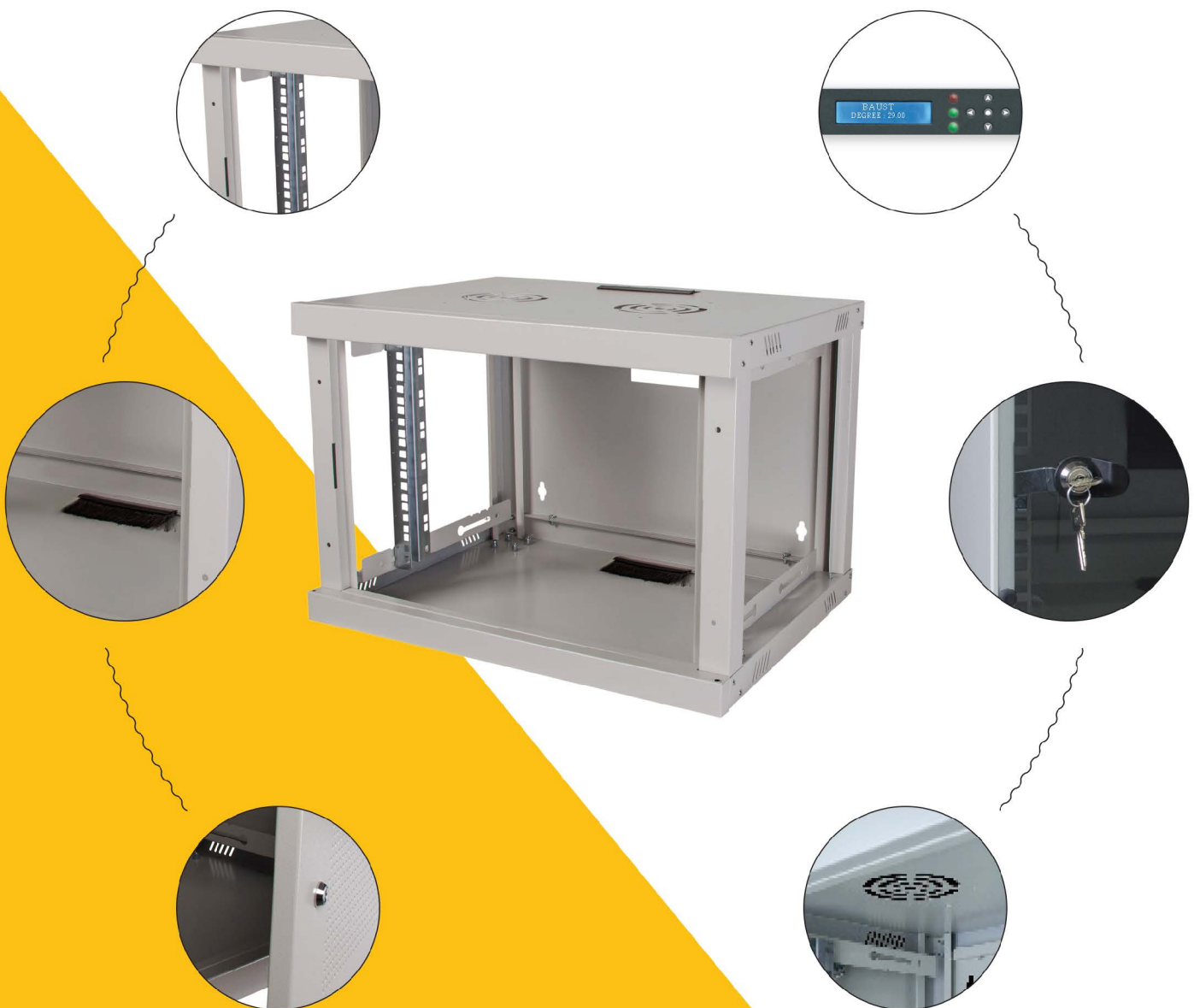

## 19" RACK CABINET PRO 600x450 Wall Type Rack Cabinet

### TECNICAL DETAILS

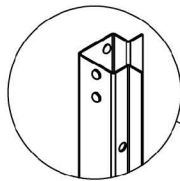

DETAIL A

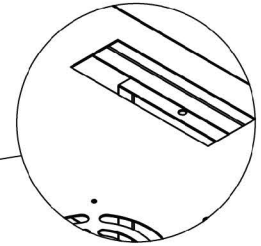

DETAIL B

Wide W: 600 mm.  
Dept D: 450 mm.  
Carrying Capacity: 80 kg.

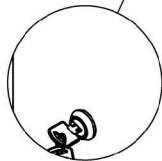
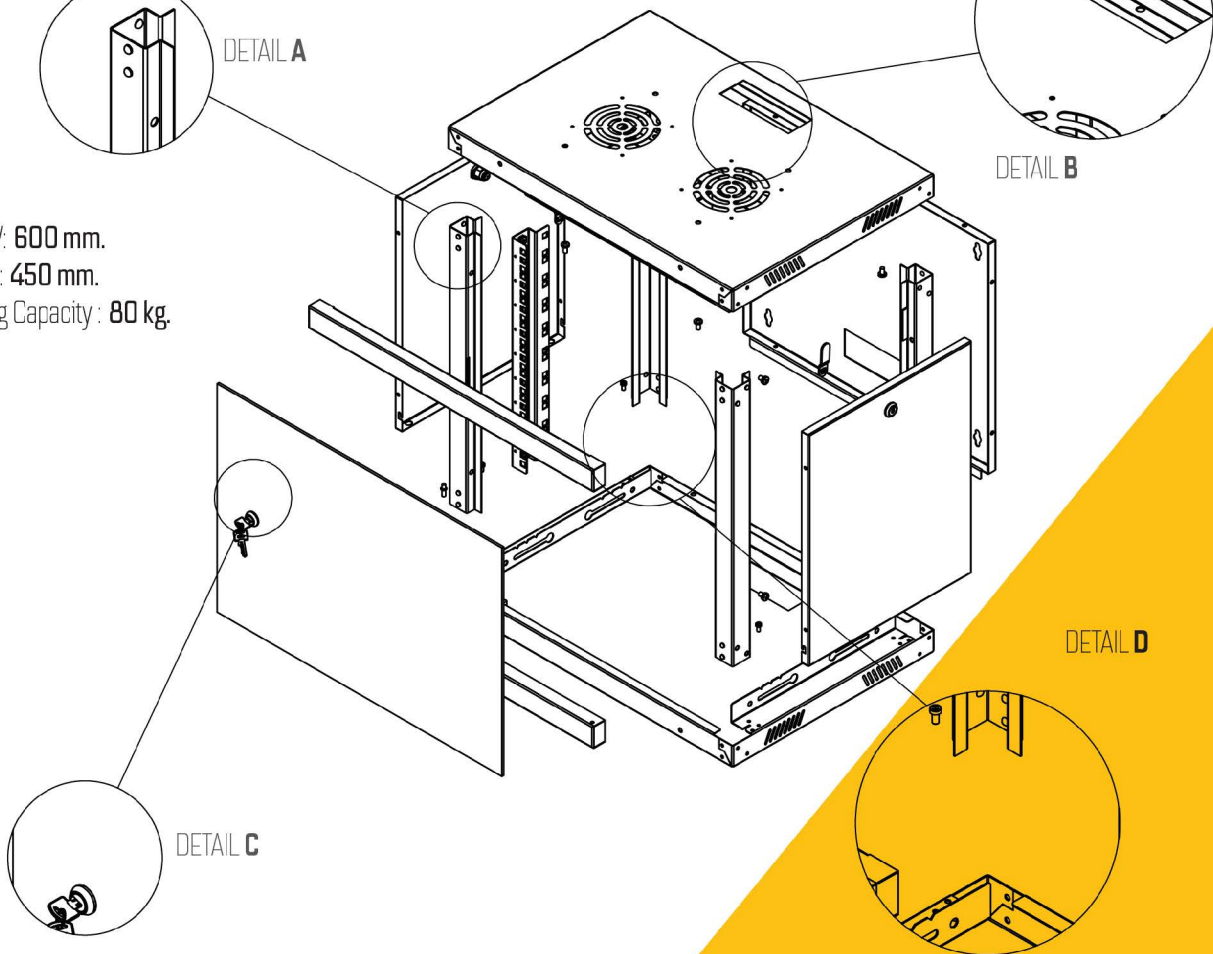

DETAIL C

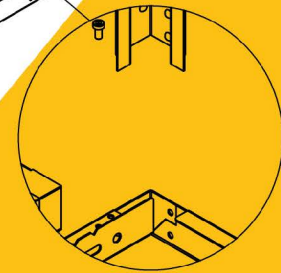

DETAIL D

Product Code	Description	Stock Code	Dimension wxdxh Mm	h Dimension U	h mm	H mm Outside Outside	Wide mm	Wide Device	Between The Bins Depth Mm	Amount in Packing	Packing Dimension WxDxH mm	Net Product Weight G.	Gross Product Weight G.	
600x450	TSPK-7U6045	7U 19" PRO WALL TYPE RACK CABINET	17061	600x450x396	7U	330	396	600	19"	450	1	620x470x416	11.100	16.200
	TSEK-9U6045	9U 19" PRO WALL TYPE RACK CABINET	17062	600x450x510	9U	425	510	600	19"	450	1	620x470x530	12.500	17.600
	TSEK-12U6045	12U 19" PRO WALL TYPE RACK CABINET	17063	600x450x680	12U	566	680	600	19"	450	1	620x470x700	14.600	19.700
600x600	TSPK-7U6060	7U 19" PRO WALL TYPE RACK CABINET	17064	600x600x396	7U	330	396	600	19"	600	1	620x620x416	11.100	16.200
	TSEK-9U6060	9U 19" PRO WALL TYPE RACK CABINET	17065	600x600x510	9U	425	510	600	19"	600	1	620x620x530	12.500	17.600
	TSEK-12U6060	12U 19" PRO WALL TYPE RACK CABINET	17066	600x600x680	12U	566	680	600	19"	600	1	620x620x700	14.600	19.700

## WALL MOUNTED ENCLOSURES

INDOOR - OUTDOOR

**Easy** to install,

Network distribution panels designed to create an efficient cost index.

Parallel to the high performance and quality of network applications, it offers an unobtrusive price index thanks to fully automated industrial infrastructure and design. The product group has the most efficient price index modeled on the required performance and qual



**Its Intelligent Design  
And Packaging,**  
it has low shipping costs  
and low storage costs.

**Each Panel** is available as a standard metal front door with lockable 'O' lock with cylindrical single point locking.



## WALL MOUNTED ENCLOSURES **500x600** INDOOR

### Wall Type Electrical / Automation / Industrial Panels:

Wall type Industrial / Automation / Electrical panels are used for internal and external environments for electrical distribution, automation and control purposes.

Wall mount or pole mount can be used. It can be used with 19 " applications with accessories.

## GENERAL FEATURES

- Metal material is boiled for high strength body is created.
- Narrow side bends provide more room for internal installation.
- The base sheet can be easily taken into or out of the panel.
- Suitable for 500 hour salt test strength, Nano-Zirconium based Henkel Bonderite Nanotechnology coating with RAL 7035 Ince rough color, 70-90 micron thick.
- Provides high strength against chemicals.
- For high strength, cover with multiple folded bends It was consolidated.
- There is a single or double lock on the cover, the lid can be adapted for opening in the opposite direction.
- Gasket is applied on the cover for sealing.
- Cable entry on the lower side depending on the size of the panel It is available.



**RAL 9005**  
Black



**RAL 7035**  
Light Grey

### Standard Production Measures Used :

Height (mm) : 600 / 700 / 800  
Width (mm) : 500 / 600 / 800  
Depth (mm) : 150 / 200 / 250  
• Can be produced in desired sizes



## WALL MOUNTED ENCLOSURES 500x600 INDOOR

### DETAILS

- The main body, bottom - top part, is created as a result of deep drawing.
- Provides extra strength against multi-jawed body and welding load handling and external impact.
- The lid structure is reinforced by strength and flatness with multiple bends and folds.
- Base plate (Mounting plate) - manufactured from galvanized sheet (including 500 mm)
- Wall mount brackets provide high-volume load handling without deformation.



### TECHNICAL DETAILS

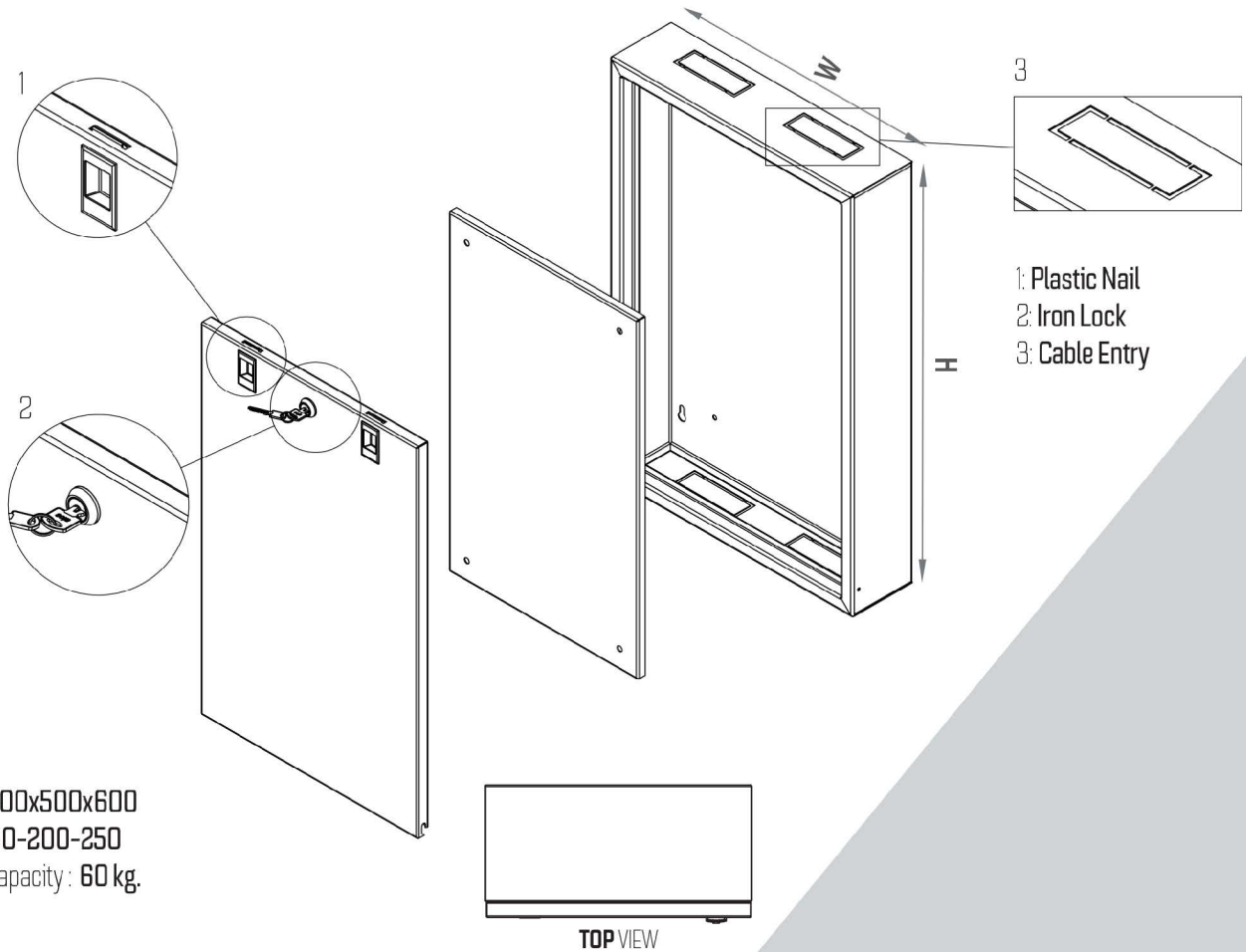

Product Code	Description	Stock Code	Dimension wxdxh Mm	Depth	H mm Outside Outside	Wide mm	Net Product Weight G.		
							150	200	250
TP-400x300	400x300 INDOOR ENCLOSURES	17061	400x300	150x200x250	300	400	4.500	6.000	7.500
TP-400x600	400x600 INDOOR ENCLOSURES	17062	400x600	150x200x250	600	400	9.000	12.000	15.000
TP-400x700	400x700 INDOOR ENCLOSURES	17063	400x700	150x200x250	700	400	10.500	14.000	17.500
TP-400x1100	400x1100 INDOOR ENCLOSURES	17064	400x1100	150x200x250	1100	400	16.500	22.000	27.700
TP-500x600	500x600 INDOOR ENCLOSURES	17065	500x600	150x200x250	600	500	9.800	13.000	16.300
TP-500x700	500x700 INDOOR ENCLOSURES	17066	500x700	150x200x250	700	500	10.000	13.200	16.500
TP-600x700	600x700 INDOOR ENCLOSURES	17067	600x700	150x200x250	700	600	12.000	16.000	20.000
TP-600x800	600x800 INDOOR ENCLOSURES	17068	600x800	150x200x250	800	600	13.700	18.200	22.800
TP-600x900	600x900 INDOOR ENCLOSURES	17069	600x900	150x200x250	900	600	15.400	20.500	25.500
TP-750x1200	750x1200 INDOOR ENCLOSURES	17070	50x1200	150x200x250	1200	750	20.500	27.300	34.200
TP-800x1200	800x1200 INDOOR ENCLOSURES	17071	800x1200	150x200x250	1200	800	19.000	25.450	31.800



## WALL MOUNTED ENCLOSURES IP55 500 mm OUTDOOR

### Improved IP55 Outdoor exterior panel

Steel construction, specially designed panel structure is resistant to bending and has a built-in screw system construction

. Protect your devices against external influences with high corrosion resistance.



**RAL 9005**  
Siyah



**RAL 7035**  
Açık Gri

### Standard Production

Measures Used:

Height (mm): 600

Width (mm) : 400

Depth (mm) : 250



## GENERAL FEATURES

**External Dimensions:** The size and design of the external type panel CINA. Four of the bases at the bottom of the board it is fixed to the hole in the corner. Fixing operation If desired, the template is used.

**Doors:** 120o openable doors are locked from two spots. Depending on the design of the doors, knows.

**Paint and surface treatment processes:** Iron surface treatment process and then painted with RAL 7035 paint. In the standard, the inner parts are made entirely of galvanized sheet is. It is produced as aluminum on demand. Electrostatic powder coating is applied.

**Protection class:** IP55 - water and dust tightness. Cable entry: otherwise if not requested, on the bottom of the board. Cooling unit: can be added. Cable entry is standard if not specified.

**Basic materials and standards:** Main carrier profiles, spools, panels and panel ceiling Dkp are produced from the material.

**Grounding:** Hinges on the underside of the inside of each door for close grounding M6 nut is attached to the spot without paint-Taste.

**Hinges:** Iron hinges with anti-vandal features, fixed in the channel in the profile of the cap it forms an extension of the door. A possible challenge from the outside It is resistant to intervention.

### DETAIL

Made of 40x40 razor stainless sheet, W 150-200 mm, width and depth according to panel size  
It varies. The type of material and the type of material used can vary according to the project request.  
Template (Optional): Proper and easy installation of the panel to be used as a guide on concrete floor  
. The panel can be fixed to the concrete with four corner M12 tittings.

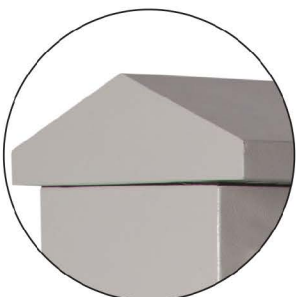

## WALL MOUNTED ENCLOSURES IP 55 500 mm OUTDOOR

### TECHNICAL DETAILS

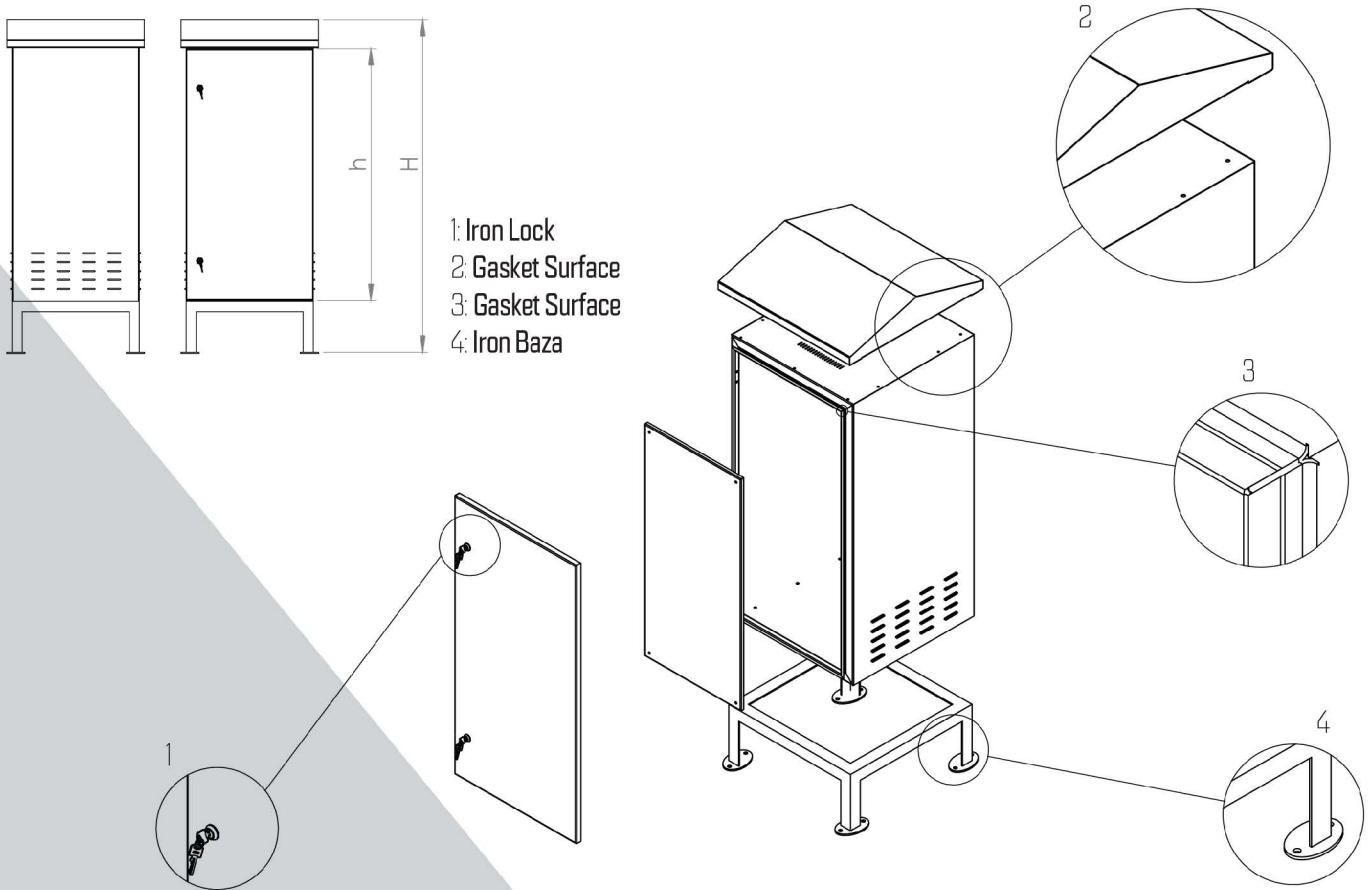

Product Code	Description	Stock Code	Dimension wxdxh Mm	Depth	H mm Outside	Wide mm	Amount in Packing	Packing Dimension WxDxH mm	Net Product Weight G.	Gross Product Weight G.
TP-500x600	500x600 OUTDOOR ENCLOSURES	17081	500x600	150x200x250	600	500	1	520x620x170	24.000	25.000
TP-500x700	500x700 OUTDOOR ENCLOSURES	17082	500x700	150x200x250	700	500	1	520x720x170	28.000	29.000
TP-500x800	500x800 OUTDOOR ENCLOSURES	17083	500x800	150x200x250	800	500	1	520x820x170	32.000	33.000
TP-500x900	500x900 OUTDOOR ENCLOSURES	17084	500x900	150x200x250	900	500	1	520x920x170	36.000	37.000



## DOUBLE INSULATION ENCLOSURES 640x400 OUTDOOR

### Pole Type Electrical / Automation / Industrial Panels:

Wall type Industrial / Automation / Electric panels, electrical distribution, automation and control control purposes It is used in internal and external environments. It can be connected to wall, pole and floor. 19 " with accessories can be used in applications.

## GENERAL FEATURES

- Metal material is boiled for high strength. body is created.
- Full compliance with edge bends and lid seal.
- Narrow side bends provide more room for internal installation.
- IP55 Provides protection against dust and water.
- Mechanical resistance against external impact is high.
- Suitable for 500 hour salt test strength, Phosphate coating and RAL 7035 is painted 70-90 micron thick paint.
- Provides high strength against chemicals.
- For high strength, cover with multiple folded bends t was consolidated.
- There is only one lock on the cover, the cover can be made suitable for opening in the reverse direction.
- Highly corrosion resistant
- There is a sealing ring on the cover.
- Cable entry on the lower side depending on the size of the panel It is available.



**RAL 9005**  
Black



**RAL 7035**  
Light Grey

### Standard Production Measures Used:

Height (mm) : 600 / 700 / 800  
Width (mm) : 500 / 600 / 800  
Depth (mm) : 150 / 200 / 250



## DOUBLE INSULATION ENCLOSURES 640x400 OUTDOOR

### DETAIL

- The main body is formed as a result of welding the lower - upper part with the baffled center piece. Provides extra strength against multi-jawed body and welding load handling and external impact.
  - The lid structure is reinforced by strength and flatness with multiple bends and folds. It provides better contact with the gasket for better sealing protection.
- Base plate (Mounting plate) - manufactured from galvanized sheet. From panels with height of 500 mm, cabling and it is manufactured by bending 4 sides (to 500 mm included) to assure the installation of the equipment.
  - Wall mount brackets provide high-volume load handling without deformation.

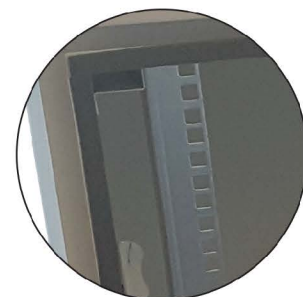

### TECHNICAL DETAILS

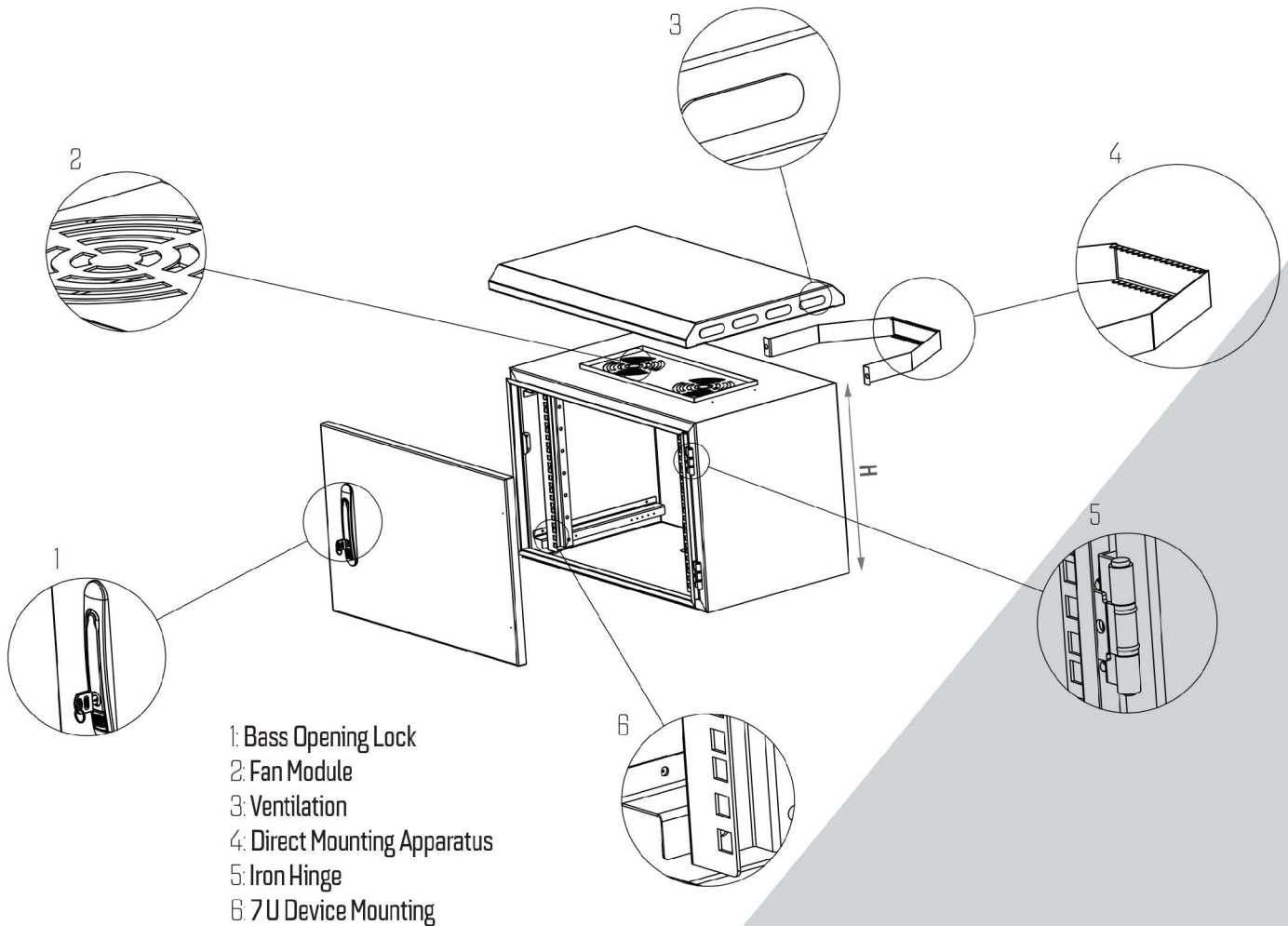

Product Code	Description	Stock Code	Dimension wxdxh Mm	h Dimension in U	H mm Outside Outside	Wide mm	Amount in Packing	Depth mm	Amount in Packing	Packing Dimension WxDxH mm	Net Product Weight G.	Gros Product Weight G.
TP-7U6440	7U OUTDOOR ENCLOSURES	17091	640x400x420	7U	420	640	19"	400	1	660x420x420	23.300	24.300
TP-9U6440	9U OUTDOOR ENCLOSURES	17092	640x400x555	9U	555	640	19"	400	1	660x420x555	29.900	30.900
TP-12U6440	12U OUTDOOR ENCLOSURES	17093	640x400x688	12U	688	640	19"	400	1	660x420x688	39.600	40.600
TP-16U6440	16U OUTDOOR ENCLOSURES	17094	640x400x821	16U	821	640	19"	400	1	660x420x821	52.800	53.800



## ACCESSORIES

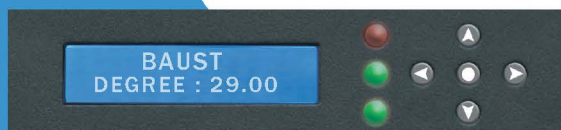



## ORGANIZER HORIZONTAL

### GENERAL FEATURES

#### Horizontal Cable Regulation Class,

The cabinets are various accessories for the management of the cables, management and transfer. 1U, 2U brushes, with hooks available. Available in RAL 9005 Black and RAL 7035 Light Gray Colors.

Stock Code: 17101	W:600 x D:600	W:600 x D:600	W:600 x D:150 entgre With additional compartments D: 450 + 150 or D: 600+150
Horizontal Cable Arrangement Panel 19" 1U 5 with hook	TYD-1U5K	TYD-2U5K	TYD-2U5K

\*\*CC: Available in RAL 9005 Black and RAL 7035 Light Gray Colors, color can be made according to customer request

## ORGANIZER VERTICAL



### GENERAL FEATURES

#### In the Vertical Cable Regulation Class,

Cabinets are cable ducts for management and transmission purposes. Cables are arranged on the slots, hyphenated it is transferred to the relevant equipment properly and manageably. By side-by-side mounting, the cable can be moved. Cable ducts reinforced with 2 bends from metal are offered in zinc plated (8-12 micron).

Stock Code: 17102	W:600 x D:600	W:600 x D:600	W:600 x D:150 entgre With additional compartments D: 450 + 150 or D: 600+150
Vertical Cable Arrangement Panel 19" 1U 5 with hook	TYD-1U5K	TYD-2U5K	TYD-2U5K

\*\*CC: Available in RAL 9005 Black and RAL 7035 Light Gray Colors, color can be made according to customer request



## SHELF FIXED

### GENERAL FEATURES

#### Fixed Shelf 4 point connected,

They are compatible with stand-up type rack cabinets. Ventilation slots are placed in order not to interfere with the ventilation system. It has been reported. It is a high-strength accessory constructed from steel material with bending technology. Carrying capacity 40 kg

Stock Code: 17103 Stock Code: 17104 Stock Code: 17105	W:400 x D:425 W:475 x D:695 W:475 x D:800	W:400 x D:425 W:475 x D:695 W:475 x D:800	W:600 x D:150 entgre With additional compartments D: 450 + 150 or D: 600+150
Fixed Shelf	TRK-SRB6060	TRK-SRB6060	TRK-SRB6060

\*\*CC: Available in RAL 9005 Black and RAL 7035 Light Gray Colors, color can be made according to customer request

## SHELF MOVABLE



### GENERAL FEATURES

**Movable Shelves** 4 point connected,

All brands are cabinet compatible products. The deeply movable device is integrated with the stand mounting ears.

Ventilation slots are provided to prevent any obstruction to the ventilation system.

Stock Code: 17106 Stock Code: 17107 Stock Code: 17108	W:400 x D:425 W:475 x D:695 W:475 x D:800	W:400 x D:425 W:475 x D:695 W:475 x D:800	W:600 x D:150 entegre With additional compartments D: 450 + 150 or D: 600+150
Movable Shelves	TRK-HR6060	TRK-SRB6060	TRK-SRB6060

\*\*CC - Available in RAL 9005 Black and RAL 7035 Light Gray Colors, color can be made according to customer request



## FAN MODULE WITH 2 and 4

### GENERAL FEATURES

**Wall type, Stylish type, Server type cabinet special,**

They are Fan Module units that can be used at their height.

Ready integrated on / off lu units with plug-and-play operation. Beher Fan capacity is 2,3-3 m3 / min air flow.

With 2 Stock Code: 17109 With 4 Stock Code: 17110	W:600 x D:450	W:600 x D:600	W:600 x D:150 entegre With additional compartments D: 450 + 150 or D: 600+150
With 1 Fan Unit on/off switch	LN-FAN-ONF-1FWM-CC	LN-FAN-ONF-1FWM-CC	LN-FAN-ONF-1FWM-CC
With 1 Fan Unit Thermostat Remote	LN-FAN-THM-1FWM-CC	LN-FAN-THM-1FWM-CC	LN-FAN-THM-1FWM-CC
With 2 Fan Unit on/off switch	LN-FAN-ONF-2FWM-CC	LN-FAN-ONF-2FWM-CC	LN-FAN-ONF-2FWM-CC
With 2 Fan Unit Thermostat Remote	LN-FAN-THM-2FWM-CC	LN-FAN-THM-2FWM-CC	LN-FAN-THM-2FWM-CC

\*\*CC - Available in RAL 9005 Black and RAL 7035 Light Gray Colors, color can be made according to customer request

## GROUP SOCKET With 6 and 9



### GENERAL FEATURES

**Aluminum Body,** different features and types,

Energy Distribution Modules. CE Certified. DIN49440 Schuko, IEC 320 C13 IEC type, BS1363 UK Plug-in types, illuminated 16A on / off, 16A Fuse Protection, Overvoltage Protection, and many other types and features.

Stock Code: 17111	W:600 x D:450	W:600 x D:600	W:600 x D:150 entegre With additional compartments D: 450 + 150 or D: 600+150
With socket 6 Schuko tip, 16A insurance	LN-PRZ-SGT-IUGP-SC	LN-PRZ-SGT-IUGP-SC	LN-PRZ-SGT-IUGP-SC





## RACK CABINET WHEEL

### GENERAL FEATURES

**Specially** designed for cabinet ...

Height-adjustable PVC Foot System and 360-degree fully-movable wheel groups on the y-axis. Each set consists of 4 pieces, wheels There are 2 brakes, 2 brakes. It is an accessory designed for connecting the cabinets to the floor.

Stock Code: 17112	W:600 x D:450	W:600 x D:600	W:600 x D:150 entegre With additional compartments D: 450 + 150 or D: 600+150
With whell groups 2 brakes, 2 brakless	LN-ZMN-TKR-5020-XX	LN-ZMN-TKR-5020-XX	LN-ZMN-TKR-5020-XX

## RACK CABINET LOCKED



### GENERAL FEATURES

**It is used** in electric panels and machine covers.

Stock Code: 17113

Raw Materials	Technical Features	Cylinder	Material	O'ring
POLYAMIDE PA6 GFR30	BODY:POLYAMIDE PA6 GFR30	ZINC DIN-EN 1774 ZnAl4Cu1	STEEL	RUBBER



## RACK CABINET THERMOSTAT

### GENERAL FEATURES

**Thanks to the** practical and ergonomic construction,

all kinds of brand and model active and passive devices can be installed in any detail accessories are manufactured in consideration of active and passive ventilation and traceability.

DEMPERATURE SENSOR	DIGITAL HEAT INDICATOR	WITH SYSTEM COOLING FAN	TEMPERATURE DETERMINION
--------------------	------------------------	-------------------------	-------------------------

Stock Code: 17114

The digital temperature sensor measures the temperature of the heat and Fan 1 and 2 enter the circuit at the specified temperature intervals. At extremely high temperatures the Buzzer Alarm is switched on and the warning buzzer sounds.

## RACK CABINET BRUSH



### GENERAL FEATURES

Stock Code: 17115	W:600 x D:450	W:600 x D:600	W:600 x D:150 entegre With additional compartments D: 450 + 150 or D: 600+150
BRUSH	-	***LN-RAF-HRK-D600-CC	***LN-RAF-HRK-D600-CC
**CC - Available in RAL 9005 Black and RAL 7035 Light Gray Colors, color can be made according to customer request			



## RACK CABINET COVERING PANEL

### GENERAL FEATURES

**Network and Storage** applications,

in order to correct the appearance by turning off the meter, which is not fitted with the device,

It is used as a stopper and a router in the passages.

19 "Closed Panels with Closed Type Tooling Units from 1U to 6U, Hand-held with special type rotatable clips mounting.

Covering panels with 2 bendings made of metal are supplied in RAL 9005 Black and RAL 7035 Light Gray Colors.

1U and 2U models are available with Slotted Ventilation

Stock Code: 17116

## RACK CABINET BOLT



### GENERAL FEATURES

**M6 Steel Cage** Nut Set,

20 and 50 packages including screws and washers, connection elements such as cabinet connection kit

Stock Code: 17117